

2MC



**Catálogo**  
*de produtos*

product catalog



É com grande prazer que apresentamos ao mercado o mais novo catálogo de produtos 2MC. Trata-se de mais uma ampliação na linha de produtos oferecida pela empresa líder em reparos de fixação do sistema de freios. São dezenas de novos itens que atendem as últimas evoluções da frota veicular do país. Assim, a 2MC antecipa mais uma vez às necessidades da cadeia de manutenção automotiva nacional, confirmando sua vocação pioneira no segmento. Todos os lançamentos estão apontados em destaque para facilitar visualizações e permitir rápidas identificações. Outra novidade desse catálogo é a introdução da nova linha de reparos da pinça de freio, agora mais completa e detalhada, com informações sobre compatibilidades e aplicações que vão facilitar o trabalho de distribuidores, varejistas e reparadores.

**A marca que você prefere, você exige, você pode contar. 2MC sempre**

<b>AK</b> asia / kia	<b>AS</b> asia	<b>CI</b> citroën	<b>FG</b> ford / gm	<b>FO</b> ford
<b>FT</b> fiat	<b>FW</b> fiat / vw	<b>GM</b> general motors	<b>HO</b> honda	<b>HY</b> hyundai
<b>IV</b> iveco	<b>KI</b> kia	<b>LG</b> fiat / ford / gm / vw	<b>MB</b> mercedes-benz	<b>MI</b> mitsubishi
<b>NI</b> nissan	<b>PG</b> peugeot	<b>RN</b> renault	<b>TY</b> toyota	<b>VW</b> volkswagen

LINHA	DESCRIÇÃO	PÁGINA
LINHA 1	KIT REPARO A DISCO	PÁG 06-11
LINHA 2	REPAROS CENTRALIZADOR DO PATIM	PÁG 12-16
LINHA 3	REPARO DA SAPATA	PÁG 16-22
LINHA 4	REGULADORES - ACIONADORES - ALAVANCAS - PINOS - HASTES	PÁG 22-36
LINHA 5	PINO DE PASTILHA	PÁG 37
LINHA 6	PARAFUSO DE SANGRIA	PÁG 37-38
LINHA 7	REPARO DO PATIM/SAPATA (COMPLETO)	PÁG 39-45
LINHA 8	REPARO DE PINÇA (PARCIAL)	PÁG 45-48
LINHA 9	REPARO DE PINÇA (COMPLETO)	PÁG 48-50
LINHA 10	REPARO DE VEDAÇÃO DA PINÇA	PÁG 52-71
LINHA 10	REPARO DO PINO GUIA DA PINÇA	PÁG 72-95
	<b>LANÇAMENTOS DESTACADOS NA COR AZUL</b>	

## Sistema de codificação

Os produtos deste catálogo foram codificados por um número que indica sua linha, duas letras que identificam a montadora, dois ou três números que indicam a posição dos produtos na linha e, em casos específicos, uma letra D ou E, que indica lado direito ou esquerdo, como mostra o exemplo a seguir.

**4** Linha 4 - Regulador de freio

**FT** Fabricante - Fiat

**42** Posição do produto na linha - N<sup>o</sup> sequencial

**D** Lado - Direito



## Kits de freio a disco



**1 AS 11** Kit de freio a disco



**1 FG 11** Kit de freio a disco



**1 FG 14** Mola trava da pastilha

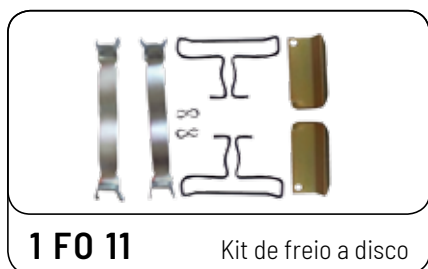

**1 FO 11** Kit de freio a disco



**1 FO 12** Kit de freio a disco

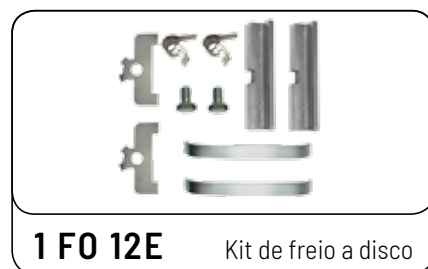

**1 FO 12E** Kit de freio a disco

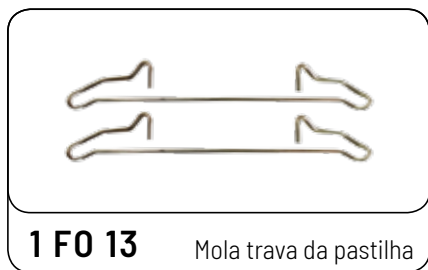

**1 FO 13** Mola trava da pastilha

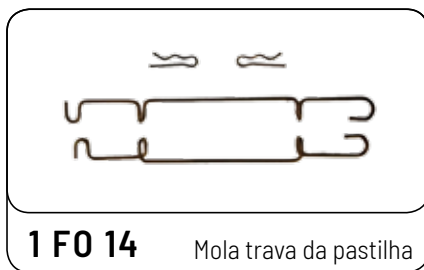

**1 FO 14** Mola trava da pastilha



**1 FO 15** Kit de freio a disco



**1 FO 16** Kit de freio a disco



**1 FO 17** Kit de freio a disco

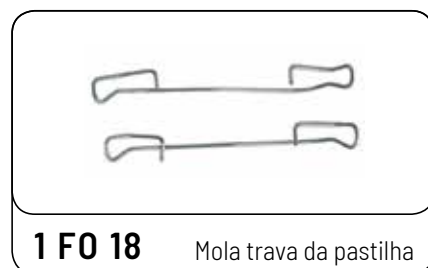

**1 FO 18** Mola trava da pastilha

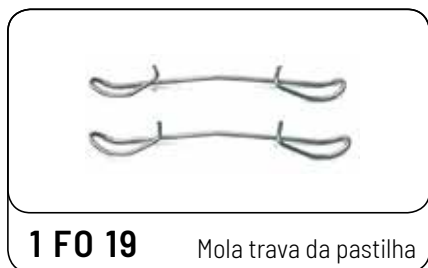

**1 FO 19** Mola trava da pastilha



**1 FO 20** Kit de freio a disco



**1 FO 21** Alinhador de pastilha



**1 FO 22** Kit de freio a disco



**1 FO 23** Kit de freio a disco



**1 FO 24** Mola trava da pastilha

# Kits de freio a disco



**1 FO 25** Alinhador da pastilha



**1 FO 26** Alinhador da pastilha



**1 FO 27** Mola trava da pastilha



**1 FO 28** Kit de freio a disco



**1 FO 29** Kit de freio a disco



**1 FO 30** Alinhador da pastilha



**1 FO 31** Kit de freio a disco



**1 FO 32** Alinhador da pastilha

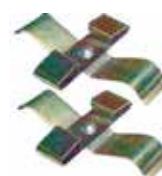

**1 FO 33** Kit de freio a disco



**1 FO 34** Alinhador da pastilha



**1 FO 35** Alinhador da pastilha

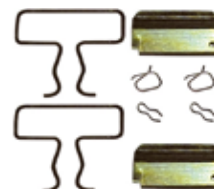

**1 FT 11** Kit de freio a disco



**1 FT 12** Kit de freio a disco



**1 FT 13** Kit de freio a disco



**1 FT 14** Kit de freio a disco



**1 FT 15** Alinhador da pastilha

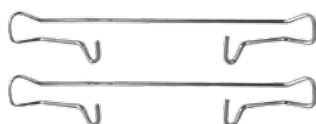

**1 FT 16** Mola trava da pastilha



**1 FT 17** Alinhador da pastilha

## Kits de freio a disco



**1 FT 18** Mola trava da pastilha

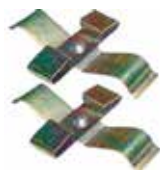

**1 FT 19** Kit de freio a disco



**1 GM 11** Kit de freio a disco



**1 GM 11E** Kit de freio a disco



**1 GM 12**



**1 GM 13** Kit de freio a disco



**1 GM 14** Mola trava da pastilha



**1 GM 15** Mola trava da pastilha

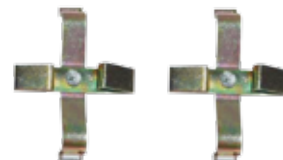

**1 GM 16** Kit de freio a disco



**1 GM 17** Kit de freio a disco



**1 GM 18** Kit de freio a disco



**1 GM 19** Kit de freio a disco



**1 GM 20** Kit de freio a disco



**1 GM 21** Kit de freio a disco



**1 GM 22** Alinhador de pastilha



**1 GM 23** Kit de freio a disco



**1 GM 24** Kit de freio a disco



**1 GM 25** Kit de freio a disco



# Kits de freio a disco



**1 GM 26** Mola trava da pastilha



**1 GM 27** Alinhador de pastilha



**1 GM 28** Mola trava da pastilha



**1 GM 29**



**1 GM 30** Alinhador de pastilha



**1 GM 31** Alinhador de pastilha



**1 GM 32** Mola trava da pastilha



**1 GM 33** Alinhador de pastilha



**1 GM 34** Kit de freio a disco



**1 GM 35** Alinhador de pastilha



**1 GM 36** Alinhador de pastilha



**1 HY 11** Alinhador de pastilha



**1 HY 12** Kit de freio a disco



**1 HY 13** Alinhador de pastilha



**1 KI 11** Alinhador de pastilha



**1 KI 12** Alinhador de pastilha

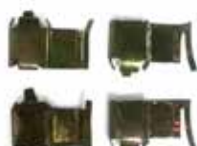

**1 KI 13** Alinhador de pastilha



**1 KI 14** Kit de freio a disco



**1 KI 15** Alinhador de pastilha



**1 LG 11** Kit de freio a disco



**1 MI 11** Alinhador de pastilha



**1 MI 12** Alinhador de pastilha



**1 MI 13** Alinhador de pastilha



**1 NI 11** Alinhador de pastilha



**1 NI 12** Alinhador de pastilha



**1 PG 21** Alinhador de pastilha



**1 RN 11** Kit de freio a disco



**1 RN 12** Kit de freio a disco

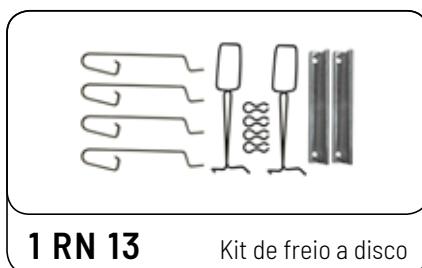

**1 RN 13** Kit de freio a disco

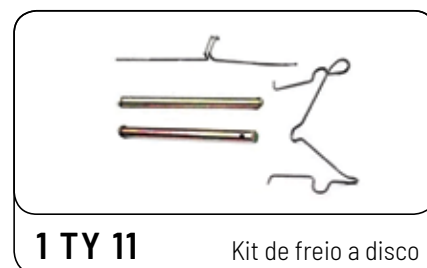

**1 TY 11** Kit de freio a disco



**1 TY 12** Alinhador de pastilha



**1 TY 13** Alinhador de pastilha



**1 TY 14** Alinhador de pastilha



**1 TY 15** Alinhador de pastilha



**1 TY 16** Kit de freio a disco



**1 TY 17** Kit de freio a disco



**1 TY 18** Alinhador de pastilha



**1 TY 19** Alinhador de pastilha



**1 TY 20** Alinhador de pastilha

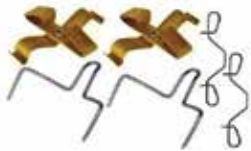

**1 VW 11** Kit de freio a disco



**1 VW 12** Kit de freio a disco



**1 VW 13** Alinhador de pastilha



**1 VW 14** Mola trava da pastilha



**1 VW 16** Kit de freio a disco



**1 VW 17** Kit de freio a disco



**1 VW 18** Kit de freio a disco

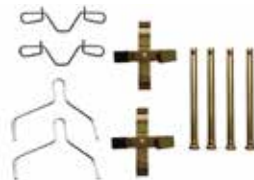

**1 VW 19** Kit de freio a disco



**1 VW 20** Kit de freio a disco

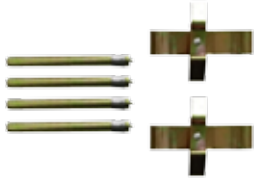

**1 VW 21** Kit de freio a disco

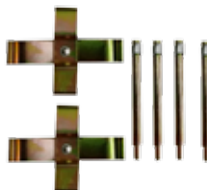

**1 VW 22** Kit de freio a disco



**1 VW 23** Kit de freio a disco



**1 VW 24** Alinhador de pastilha



**1 VW 25** Alinhador de pastilha



**1 VW 26** Alinhador de pastilha



**2 AK 21** Centralizador de freio



**2 FO 21** Centralizador de freio



**2 FO 23** Centralizador de freio



**2 FO 24** Centralizador de freio



**2 FO 28** Centralizador de freio



**2 FO 29** Centralizador de freio



**2 FO 30** Centralizador de freio



**2 FO 31** Centralizador de freio



**2 FO 32** Centralizador de freio



**2 FO 33** Centralizador de freio



**2 FO 34** Centralizador de freio



**2 FO 35** Centralizador de freio



**2 FO 36** Centralizador de freio



**2 FO 37** Centralizador de freio



**2 FO 39** Centralizador de freio



**2 FO 40** Centralizador de freio



**2 FO 41** Centralizador de freio



**2 FO 42** Centralizador de freio

**2 FO 43** Centralizador de freio**2 FO 44** Centralizador de freio**2 FT 21** Centralizador de freio**2 FT 22** Centralizador de freio**2 FT 23** Centralizador de freio**2 FT 24** Centralizador de freio**2 FT 25** Centralizador de freio**2 FT 26** Centralizador de freio**2 FT 27** Centralizador de freio**2 FT 28** Centralizador de freio**2 FT 29** Centralizador de freio**2 GM 23** Centralizador de freio**2 GM 24** Centralizador de freio**2 GM 25** Centralizador de freio**2 GM 27** Centralizador de freio**2 GM 28** Centralizador de freio**2 GM 29** Centralizador de freio**2 GM 30** Centralizador de freio



**2 GM 32** Centralizador de freio



**2 GM 33** Centralizador de freio



**2 GM 34** Centralizador de freio



**2 GM 35** Centralizador de freio



**2 GM 36** Centralizador de freio



**2 GM 37** Centralizador de freio



**2 GM 38** Centralizador de freio



**2 GM 39** Centralizador de freio



**2 GM 40** Centralizador de freio



**2 GM 41** Centralizador de freio



**2 GM 42** Centralizador de freio



**2 GM 43** Centralizador de freio

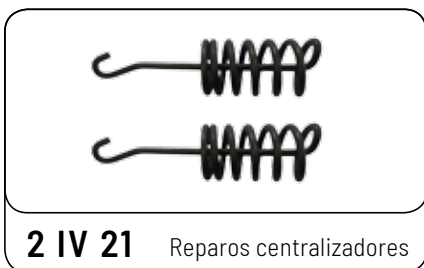

**2 IV 21** Reparos centralizadores



**2 MB 21** Centralizador de freio



**2 MB 23** Centralizador de freio



**2 MB 24** Centralizador de freio



**2 MI 21** Centralizador de freio

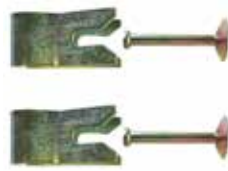

**2 MI 22** Centralizador de freio

**2 MI 23** Centralizador de freio**2 MI 24** Centralizador de freio**2 MI 25** Centralizador de freio**2 NI 21** Centralizador de freio**2 NI 22** Centralizador de freio**2 PG 21** Centralizador de freio**2 PG 22** Centralizador de freio**2 RN 21** Centralizador de freio**2 TY 21** Centralizador de freio**2 TY 22** Centralizador de freio**2 TY 23** Centralizador de freio**2 TY 24** Centralizador de freio**2 TY 25** Centralizador de freio**2 VW 21** Centralizador de freio**2 VW 22** Centralizador de freio**2 VW 23** Centralizador de freio**2 VW 24** Centralizador de freio**2 VW 25** Centralizador de freio



**2 VW 26** Centralizador de freio



**2 VW 27** Centralizador de freio



**2 VW 28** Centralizador de freio



**2 VW 29** Centralizador de freio



**2 VW 30** Centralizador de freio



**2 VW 31** Centralizador de freio



**2 VW 32** Centralizador de freio



**2 VW 33** Centralizador de freio



**2 VW 34** Centralizador de freio

# Reparos da sapata



**3 AK 31** Reparo da sapata



**3 FO 31** Reparo da sapata

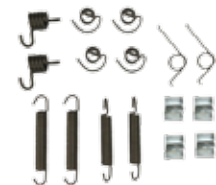

**3 FO 33** Reparo da sapata



**3 FO 35** Reparo da sapata



**3 FO 36** Reparo da sapata

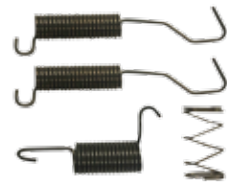

**3 FO 39** Reparo da sapata



**3 FO 43**

Reparo da sapata

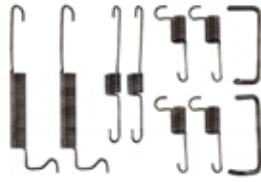
**3 FO 44**

Reparo da sapata

**3 FO 45**

Reparo da sapata

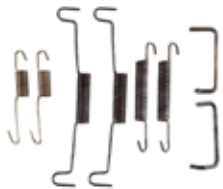
**3 FO 46**

Reparo da sapata

**3 FO 47**

Reparo da sapata

**3 FO 48**

Reparo da sapata

**3 FO 50**

Reparo da sapata

**3 FO 51**

Reparo da sapata

**3 FO 52**

Reparo da sapata

**3 FO 53**

Reparo da sapata

**3 FO 55**

Reparo da sapata

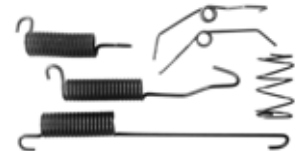
**3 FO 57**

Reparo da sapata

**3 FO 58**

Reparo da sapata

**3 FO 59**

Reparo da sapata

**3 FO 60**

Reparo da sapata

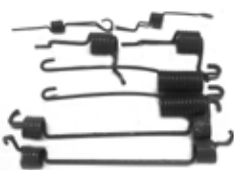
**3 FO 61**

Reparo da sapata

**3 FO 62**

Reparo da sapata

**3 FT 33**

Reparo da sapata

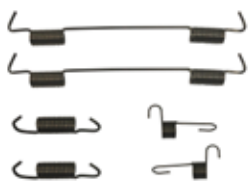

**3 FT 34**

Reparo da sapata

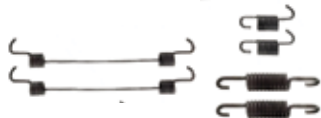

**3 FT 35**

Reparo da sapata



**3 FT 36**

Reparo da sapata



**3 FT 37**

Reparo da sapata

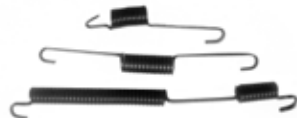

**3 FT 38**

Reparo da sapata



**3 FT 39**

Reparo da sapata



**3 FT 40**

Reparo da sapata



**3 FT 41**

Reparo da sapata



**3 FW 31**

Reparo da sapata



**3 FW 32**

Reparo da sapata



**3 GM 31**

Reparo da sapata



**3 GM 33**

Reparo da sapata



**3 GM 35**

Reparo da sapata

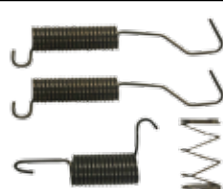

**3 GM 36**

Reparo da sapata



**3 GM 37**

Reparo da sapata



**3 GM 40**

Reparo da sapata



**3 GM 42**

Reparo da sapata



**3 GM 45**

Reparo da sapata

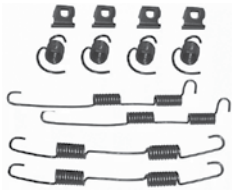
**3 GM 46**

Reparo da sapata

**3 GM 47**

Reparo da sapata

**3 GM 48**

Reparo da sapata

**3 GM 49**

Reparo da sapata

**3 GM 50**

Reparo da sapata

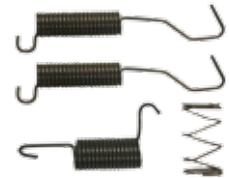
**3 GM 51**

Reparo da sapata

**3 GM 52**

Reparo da sapata

**3 GM 53**

Reparo da sapata

**3 GM 56**

Reparo da sapata

**3 GM 57**

Reparo da sapata

**3 GM 58**

Reparo da sapata

**3 GM 59**

Reparo da sapata

**3 HO 31**

Reparo da sapata

**3 HY 32**

Reparo da sapata

**3 IV 31**

Reparo da sapata

**3 IV 32**

Reparo da sapata

**3 MB 31**

Reparo da sapata

**3 MB 32**

Reparo da sapata



**3 TY 31**

Reparo da sapata

**3 TY 32**

Reparo da sapata

**3 TY 33**

Reparo da sapata

**3 TY 34**

Reparo da sapata

**3 VW 31**

Reparo da sapata

**3 VW 32**

Reparo da sapata

**3 VW 33**

Reparo da sapata

**3 VW 34**

Reparo da sapata

**3 VW 35**

Reparo da sapata

**3 VW 36**

Reparo da sapata

**3 VW 37**

Reparo da sapata

**3 VW 38**

Reparo da sapata

**3 VW 39**

Reparo da sapata

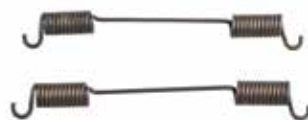
**3 VW 40**

Reparo da sapata



Reparo da sapata

**3 VW 42**

Reparo da sapata

**3 VW 43**

Reparo da sapata

**3 VW 44**

Reparo da sapata



**3 VW 45**    Reparo da sapata



**3 VW 46**    Reparo da sapata



**3 VW 47**    Reparo da sapata

## reguladores / acionadores / alavancas / pinos / hastes



**4 AK 41D**    Regulador de freio



**4 AK 41E**    Regulador de freio



**4 CI 41D**    Regulador de freio



**4 CI 41E**    Regulador de freio



**4 CI 42D**    Regulador de freio



**4 CI 42E**    Regulador de freio



**4 FG 53D**    Regulador de freio



**4 FG 53E**    Regulador de freio



**4 FG 54D**    Regulador de freio



**4 FG 54E**    Regulador de freio



**4 FG 56D**    Regulador de freio



**4 FG 56E**    Regulador de freio

**4 FG 57D** Regulador de freio**4 FG 57E** Regulador de freio**4 FG 58** Regulador de freio**4 FO 41** Regulador de freio**4 FO 42** Regulador de freio**4 FO 43** Regulador de freio**4 FO 44** Regulador de freio**4 FO 45D** Regulador de freio**4 FO 45E** Regulador de freio**4 FO 46** Regulador de freio**4 FO 46D** Regulador de freio**4 FO 46E** Regulador de freio**4 FO 47** Regulador de freio**4 FO 48D** Regulador de freio**4 FO 48E** Regulador de freio**4 FO 49D** Regulador de freio**4 FO 49E** Regulador de freio**4 FO 50** Regulador de freio



**4 FO 51D** Regulador de freio



**4 FO 51E** Regulador de freio



**4 FO 52** Regulador de freio



**4 FO 53D** Regulador de freio



**4 FO 53E** Regulador de freio



**4 FO 54D** Regulador de freio



**4 FO 54E** Regulador de freio



**4 FO 55D** Acionador de freio



**4 FO 55E** Acionador de freio



**4 FO 56D** Acionador de freio



**4 FO 56E** Acionador de freio



**4 FO 57D** Regulador de freio



**4 FO 57E** Regulador de freio



**4 FO 58D** Alavanca da sapata



**4 FO 58E** Alavanca da sapata



**4 FO 59** Haste de acionamento



**4 FO 59D** Haste de apoio



**4 FO 59E** Haste de apoio



**4 FO 60D** Haste de acionamento**4 FO 60E** Regulador de freio**4 FO 61D** Regulador de freio**4 FO 61E** Regulador de freio**4 FO 62D** Regulador de freio**4 FO 62E** Regulador de freio**4 FO 63D** Acionador de freio**4 FO 63E** Acionador de freio**4 FO 64D** Acionador de freio**4 FO 64E** Acionador de freio**4 FO 65D** Acionador de freio**4 FO 65E** Acionador de freio**4 FO 66D** Acionador de freio**4 FO 66E** Acionador de freio**4 FO 67D** Regulador de freio**4 FO 67E** Regulador de freio**4 FO 69D** Regulador de freio**4 FO 69E** Regulador de freio



**4 FO 70** Regulador de freio



**4 FO 71D** Regulador de freio



**4 FO 71E** Regulador de freio



**4 FO 72D** Regulador de freio



**4 FO 72E** Regulador de freio



**4 FT 41** Regulador de freio



**4 FT 42D** Regulador de freio



**4 FT 42E** Regulador de freio



**4 FT 43D** Regulador de freio



**4 FT 43E** Regulador de freio

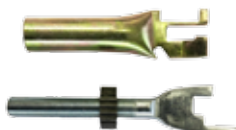

**4 FT 44D** Regulador de freio



**4 FT 44E** Regulador de freio



**4 FT 46D** Regulador de freio



**4 FT 46E** Regulador de freio



**4 FT 47D** Regulador de freio



**4 FT 47E** Regulador de freio



**4 FT 48** Regulador de freio



**4 FT 49** Regulador de freio



**4 FT 50** Regulador de freio



**4 FT 52D** Regulador de freio



**4 FT 52E** Regulador de freio



**4 FT 53** Regulador de freio



**4 FT 54D** Acionador de freio



**4 FT 54E** Regulador de freio



**4 FT 55D** Regulador de freio



**4 FT 55E** Regulador de freio



**4 FT 56D** Regulador de freio



**4 FT 56E** Regulador de freio



**4 FT 57D** Regulador de freio



**4 FT 57E** Regulador de freio



**4 FW 41D** Haste da sapata



**4 FW 41E** Haste da sapata



**4 GM 41** Pino do cilindro



**4 GM 42** Pino do cilindro



**4 GM 43** Pino da pastilha



**4 GM 44** Pino âncora



**4 GM 44A**

Pino âncora



**4 GM 45D**

Regulador de freio



**4 GM 45E**

Regulador de freio



**4 GM 46**

Regulador de freio



**4 GM 46D**

Regulador de freio



**4 GM 46E**

Regulador de freio



**4 GM 47**

Regulador de freio



**4 GM 48D**

Regulador de freio



**4 GM 48E**

Regulador de freio



**4 GM 49D**

Regulador de freio



**4 GM 49E**

Regulador de freio



**4 GM 52D**

Regulador de freio



**4 GM 52E**

Regulador de freio



**4 GM 53D**

Regulador de freio



**4 GM 53E**

Regulador de freio

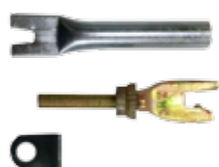

**4 GM 54D**

Regulador de freio



**4 GM 54E**

Regulador de freio



**4 GM 55D**

Regulador de freio



**4 GM 55E** Regulador de freio



**4 GM 56D** Regulador de freio



**4 GM 56E** Regulador de freio



**4 GM 57D** Regulador de freio



**4 GM 57E** Regulador de freio



**4 GM 58D** Regulador de freio



**4 GM 58E** Regulador de freio



**4 GM 59** Haste acionamento



**4 GM 59D** Alavanca de acionamento da sapata



**4 GM 59E** Alavanca de acionamento da sapata



**4 GM 60** Haste de acionamento da sapata



**4 GM 61D** Alavanca de acionamento da sapata



**4 GM 61E** Alavanca de acionamento da sapata



**4 GM 62** Haste de acionamento da sapata



**4 GM 63D** Acionador de freio



**4 GM 63E** Acionador de freio



**4 GM 66D** Regulador de freio



**4 GM 66E** Regulador de freio

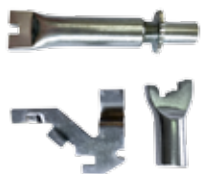

**4 GM 68D** Regulador de freio



**4 GM 68E** Regulador de freio



**4 GM 70D** Regulador de freio



**4 GM 70E** Regulador de freio



**4 GM 71D** Regulador de freio



**4 GM 71E** Regulador de freio



**4 GM 72D** Regulador de freio



**4 GM 72E** Regulador de freio



**4 GM 73D** Regulador de freio



**4 GM 73E** Regulador de freio



**4 GM 74D** Gatilho de acionamento de freio



**4 GM 74E** Gatilho de acionamento de freio



**4 GM 75D** Regulador de freio



**4 GM 75E** Regulador de freio



**4 HY 41D** Acionador de freio



**4 HY 41E** Acionador de freio



**4 HY 42D** Regulador de freio



**4 HY 42E** Regulador de freio

**4 HY 43D** Regulador de freio**4 HY 43E** Regulador de freio**4 HY 44D** Regulador de freio**4 HY 44E** Regulador de freio**4 HY 45D** Regulador de freio**4 HY 45E** Regulador de freio**4 KI 41D** Regulador de freio**4 KI 41E** Regulador de freio**4 LG 43** Regulador de freio**4 MB 41** Pino do cilindro do freio**4 MB 42** Pino do cilindro do freio**4 MB 43** Pino da sapata**4 MB 44** Pino da sapata**4 MB 45** Pino da sapata**4 MB 47** Pino da sapata**4 MB 48** Pino da sapata**4 MB 49** Pino da sapata**4 MB 50** Pino da sapata



**4 MB 51**

Pino da sapata



**4 MB 52**

Pino da sapata



**4 MB 53**

Regulador de freio



**4 MB 54**

Regulador de freio



**4 MB 55**

Regulador de freio



**4 MB 56**

Regulador de freio



**4 MB 57**

Regulador de freio



**4 MB 58**

Haste do freio de mão



**4 MB 59D**

Alavanca da sapata de freio



**4 MB 59E**

Alavanca da sapata de freio



**4 MB 60**

Kit de fixação da sapata



**4 MB 61**

Alanca da sapata de freio



**4 MB 62D**

Acionador de freio



**4 MB 62E**

Acionador de freio



**4 MB 63D**

Regulador automático



**4 MB 63E**

Regulador automático



**4 MB 65D**

Jogo de alavancas de acionamento do patim



**4 MB 65E**

Jogo de alavancas de acionamento do patim



**4 MB 66D** Regulador de freio**4 MB 66E** Regulador de freio**4 MI 41D** Regulador de freio**4 MI 41E** Regulador de freio**4 MI 42D** Alavanca de freio**4 MI 42E** Alavanca de freio**4 MI 43D** Regulador de freio**4 MI 43E** Regulador de freio**4 MI 44D** Regulador de freio**4 MI 44E** Pino do cilindro do freio**4 MI 45D** Acionador de freio**4 MI 46D** Gatilho de acionamento de freio**4 MI 46E** Gatilho de acionamento de freio**4 MI 47D** Regulador de freio**4 MI 47E** Regulador de freio**4 NI 41D** Regulador de freio**4 NI 41E** Regulador de freio**4 NI 42D** Regulador de freio



**4 NI 42E** Regulador de freio

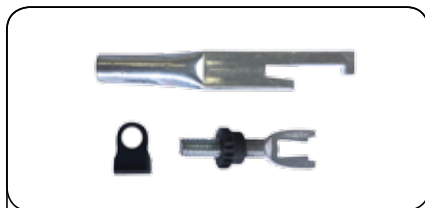

**4 PG 41D** Regulador de freio

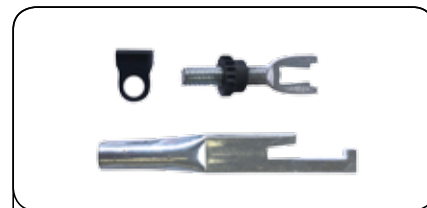

**4 PG 41E** Regulador de freio



**4 PG 42D** Regulador de freio



**4 PG 42E** Regulador de freio



**4 PG 43D** Regulador de freio



**4 PG 43E** Regulador de freio

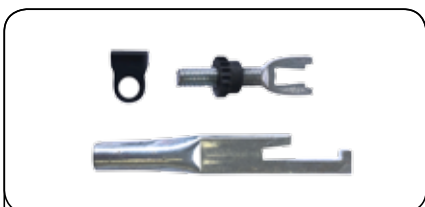

**4 RN 41D** Regulador de freio

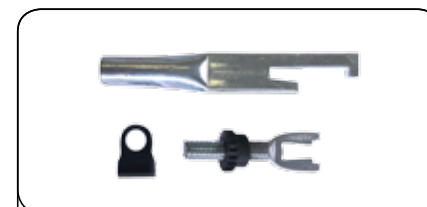

**4 RN 41E** Regulador de freio

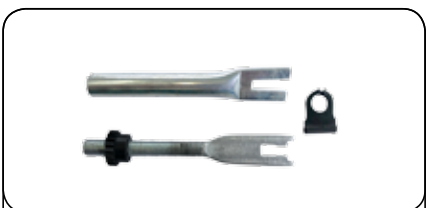

**4 RN 42D** Regulador de freio



**4 RN 42E** Regulador de freio

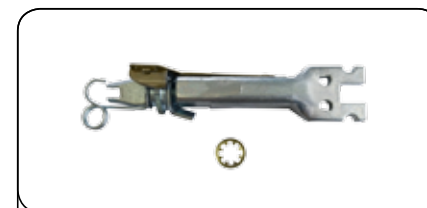

**4 RN 43D** Regulador de freio

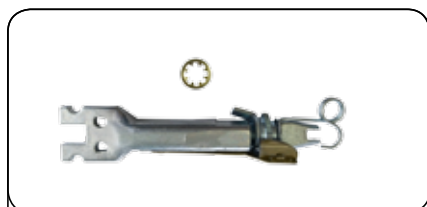

**4 RN 43E** Regulador de freio



**4 RN 44D** Regulador de freio



**4 RN 44E** Regulador de freio



**4 RN 45D** Regulador de freio



**4 RN 45E** Regulador de freio

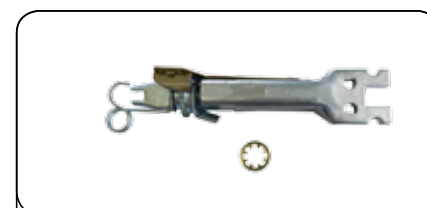

**4 RN 47D** Regulador de freio



**4 RN 47E** Regulador de freio



**4 TY 41** Regulador de freio



**4 TY 42** Regulador de freio



**4 TY 43** Regulador de freio



**4 TY 45D** Regulador de freio



**4 TY 45E** Regulador de freio



**4 TY 46D** Regulador de freio



**4 TY 46E** Regulador de freio



**4 TY 48D** Regulador de freio



**4 TY 48E** Regulador de freio



**4 TY 49D** Kit acionador de freio



**4 TY 49E** Kit acionador de freio



**4 TY 51D** Alavanca da sapata de freio



**4 TY 51E** Alavanca da sapata de freio



**4 VW 41** Regulador de freio



**4 VW 42** Regulador de freio



**4 VW 43D** Regulador de freio



**4 VW 43E** Regulador de freio



**4 VW 44**

Pino do cilindro de freio



**4 VW 45**

Regulador de freio



**4 VW 46D**

Regulador de freio



**4 VW 46E**

Regulador de freio



**4 VW 47D**

Regulador de freio



**4 VW 47E**

Regulador de freio



**4 VW 48D**

Kit alavanca da sapata



**4 VW 48E**

Kit alavanca da sapata



**4 VW 49D**

Alavanca de freio



**4 VW 49E**

Alavanca de freio



**4 VW 50D**

Alavanca de freio



**4 VW 50E**

Alavanca de freio



**4 VW 52D**

Alavanca de freio



**4 VW 52E**

Alavanca de freio



**4 VW 58D**

Regulador de freio



**4 VW 58E**

Regulador de freio



**4 VW 59D**

Acionador de freio



**4 VW 59E**

Acionador de freio

**5 FO 51**

Pino trava da pastilha

**5 FO 52**

Pino trava da pastilha

**5 FT 51**

Pino trava da pastilha

**5 GM 51**

Pino trava da pastilha

**5 GM 52**

Pino trava da pastilha

**5 GM 53**

Pino trava da pastilha

**5 TY 51**

Pino trava da pastilha

**5 VW 51**

Pino trava da pastilha

**5 VW 52**

Pino trava da pastilha

**5 VW 53**

Pino trava da pastilha

**5 VW 54**

Pino trava da pastilha

**6 FG 61**

Parafuso de sangria

**6 FG 62**

Parafuso de sangria

**6 FG 63**

Parafuso de sangria



**6 FO 61** Parafuso de sangria



**6 FT 61** Parafuso de sangria



**6 FT 62** Parafuso de sangria



**6 FW 61** Parafuso de sangria



**6 GM 61** Parafuso de sangria



**6 GM 62** Parafuso de sangria



**6 GM 63** Parafuso de sangria



**6 GM 64** Parafuso de sangria



**6 GM 65** Parafuso de sangria



**6 GM 66** Parafuso de sangria



**6 GM 67** Parafuso de sangria



**6 GM 68** Parafuso de sangria



**6 GM 69** Parafuso de sangria



**6 MB 61** Parafuso de sangria



**6 VW 61** Parafuso de sangria



**6 VW 62** Parafuso de sangria



**6 VW 63** Parafuso de sangria



**6 VW 64** Parafuso de sangria

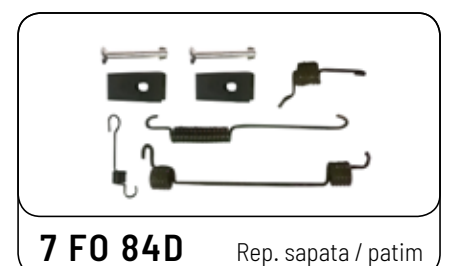
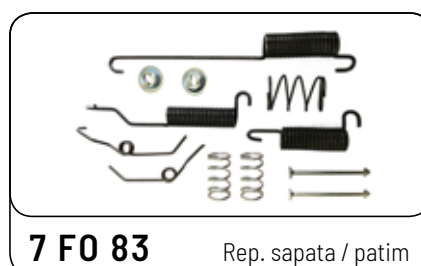
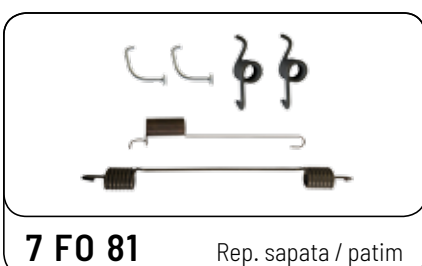
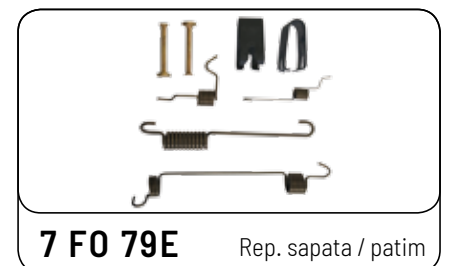
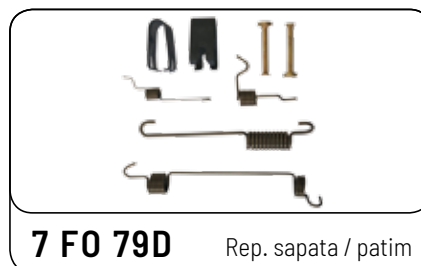
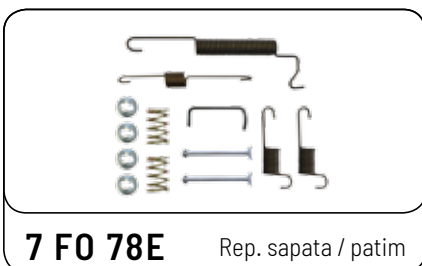
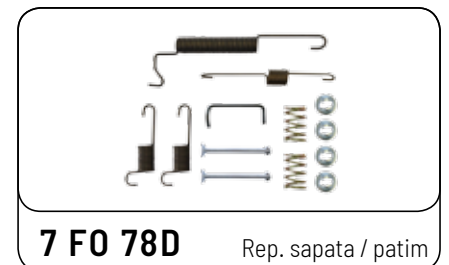
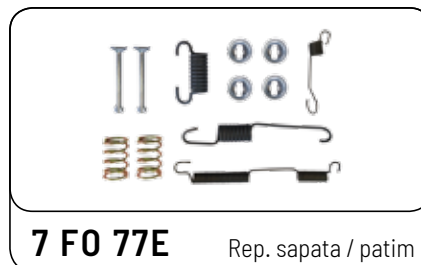
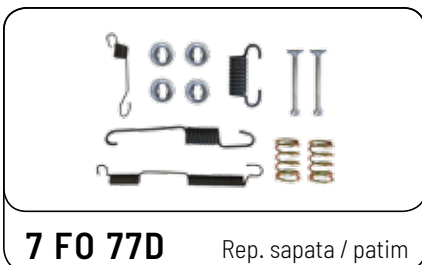
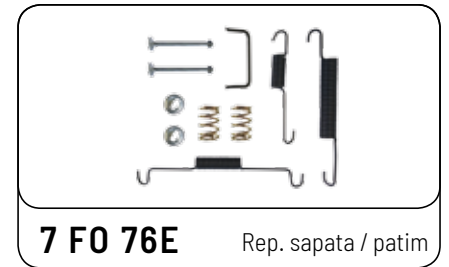
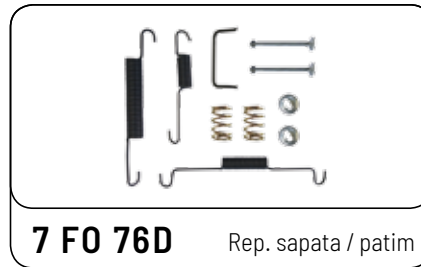
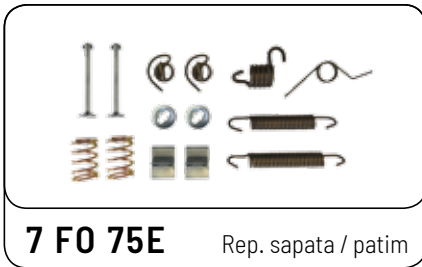
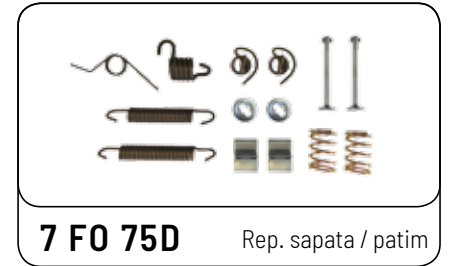
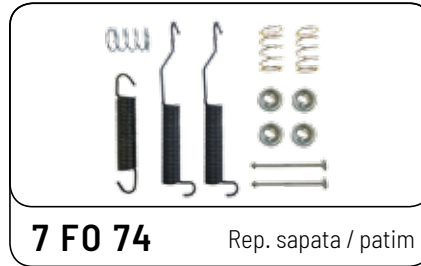
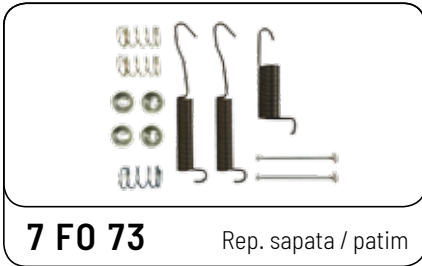
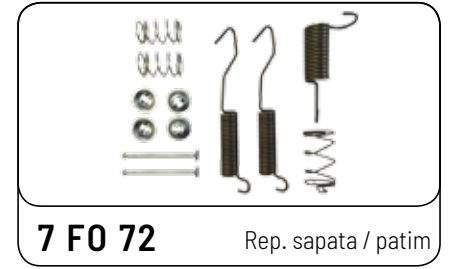
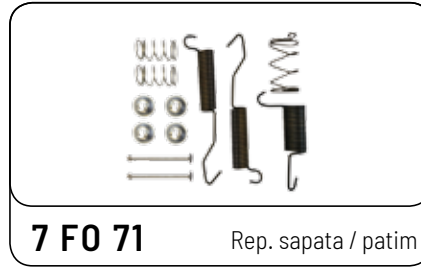
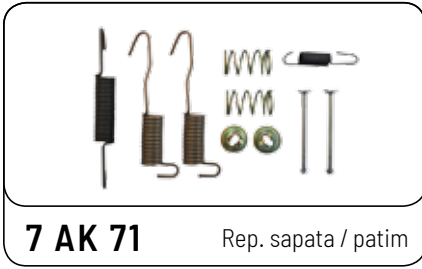

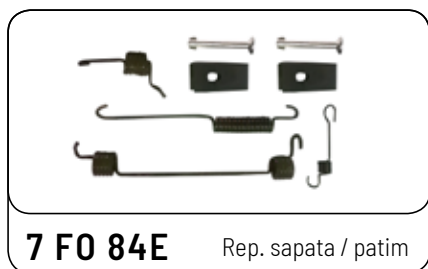

**7 FO 84E** Rep. sapata / patim



**7 FO 85** Rep. sapata / patim

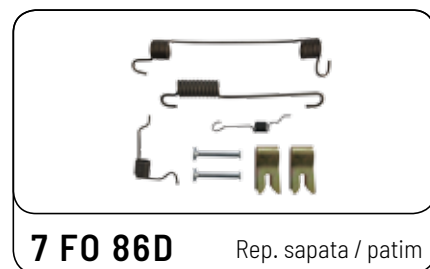

**7 FO 86D** Rep. sapata / patim

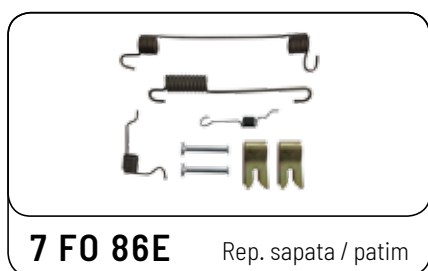

**7 FO 86E** Rep. sapata / patim

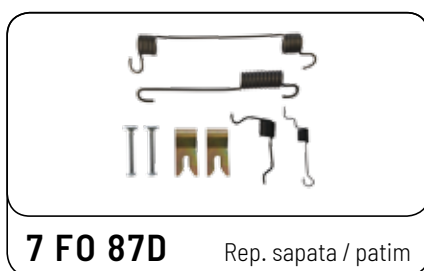

**7 FO 87D** Rep. sapata / patim

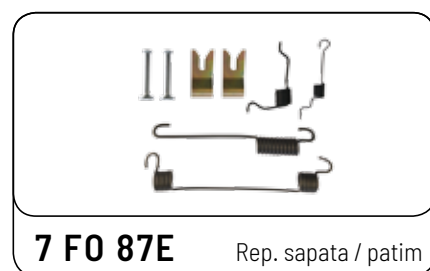

**7 FO 87E** Rep. sapata / patim

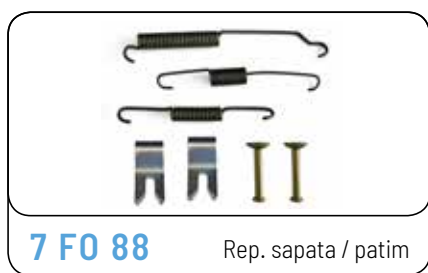

**7 FO 88** Rep. sapata / patim

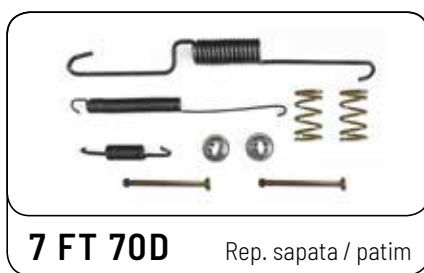

**7 FT 70D** Rep. sapata / patim



**7 FT 70E** Rep. sapata / patim

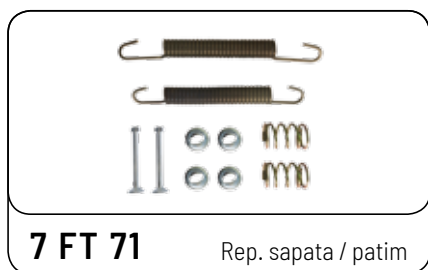

**7 FT 71** Rep. sapata / patim

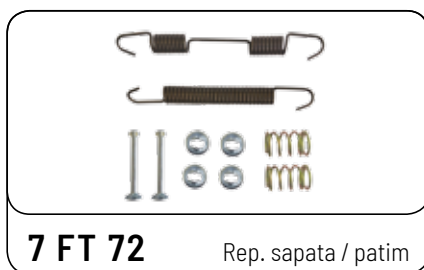

**7 FT 72** Rep. sapata / patim

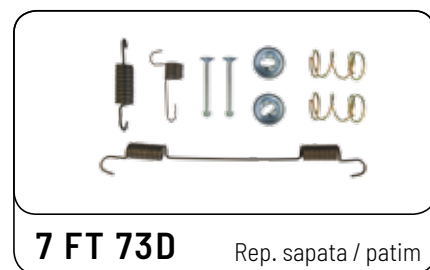

**7 FT 73D** Rep. sapata / patim



**7 FT 73E** Rep. sapata / patim

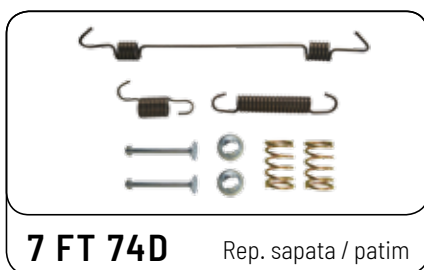

**7 FT 74D** Rep. sapata / patim

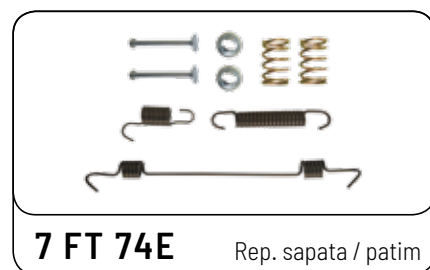

**7 FT 74E** Rep. sapata / patim

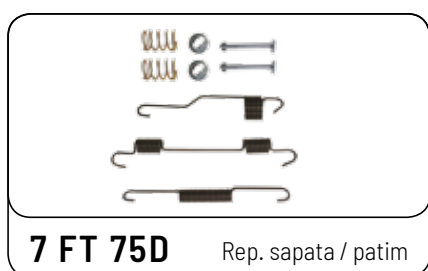

**7 FT 75D** Rep. sapata / patim

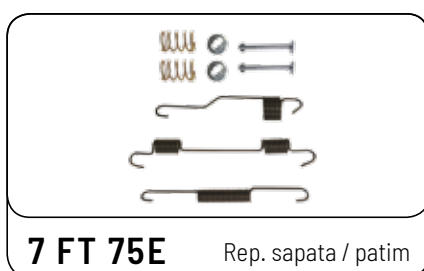

**7 FT 75E** Rep. sapata / patim

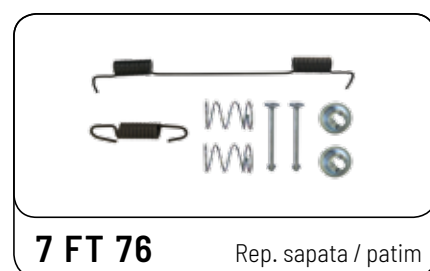

**7 FT 76** Rep. sapata / patim

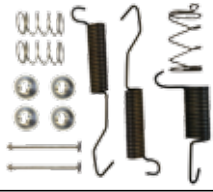
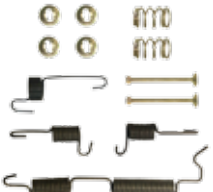
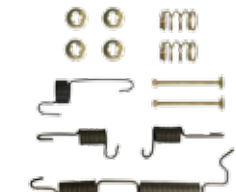
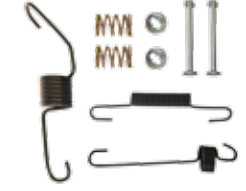
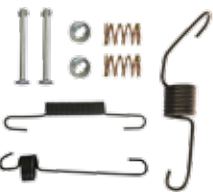
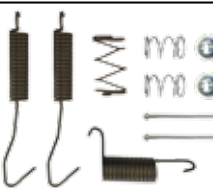
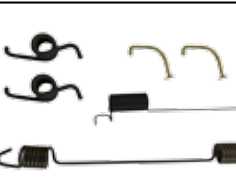

**7 GM 71** Rep. sapata / patim**7 GM 72** Rep. sapata / patim**7 GM 73D** Rep. sapata / patim**7 GM 73E** Rep. sapata / patim**7 GM 74D** Rep. sapata / patim**7 GM 74E** Rep. sapata / patim**7 GM 75D** Rep. sapata / patim**7 GM 75E** Rep. sapata / patim**7 GM 76** Rep. sapata / patim**7 GM 77D** Rep. sapata / patim**7 GM 77E** Rep. sapata / patim**7 GM 78D** Rep. sapata / patim**7 GM 78E** Rep. sapata / patim**7 GM 79D** Rep. sapata / patim**7 GM 79E** Rep. sapata / patim**7 GM 80** Rep. sapata / patim**7 GM 81** Rep. sapata / patim**7 GM 82D** Rep. sapata / patim

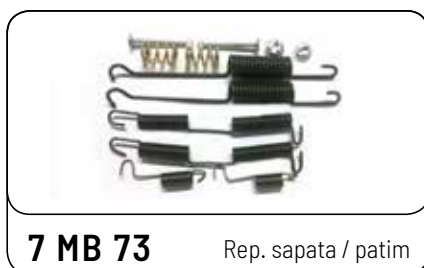
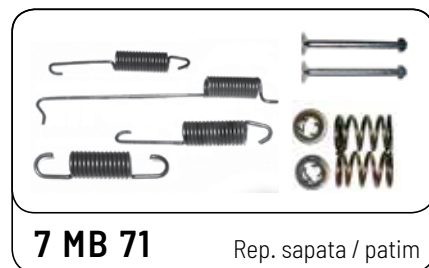
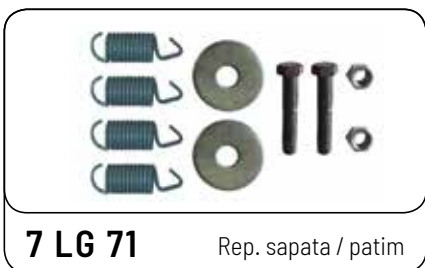
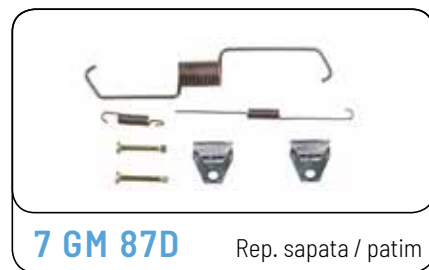
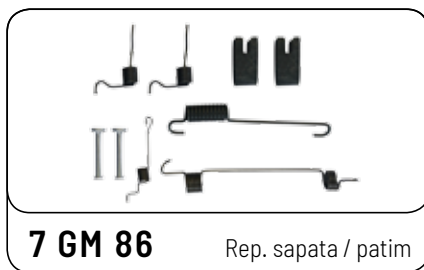
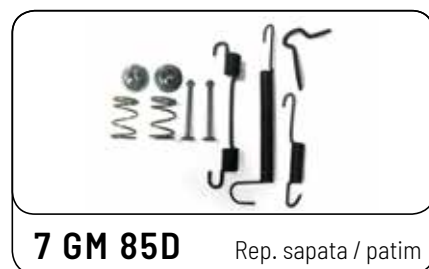
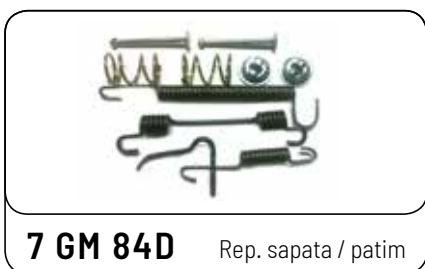
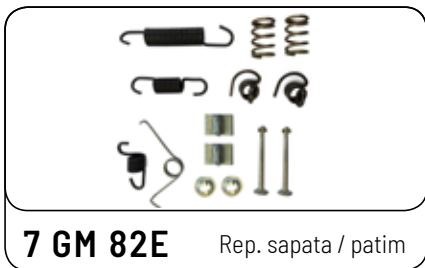



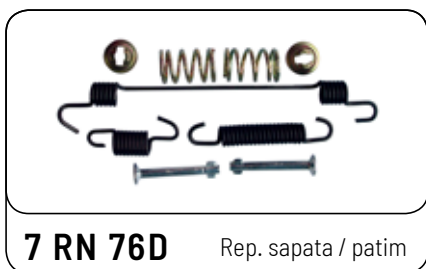

**7 RN 76D** Rep. sapata / patim

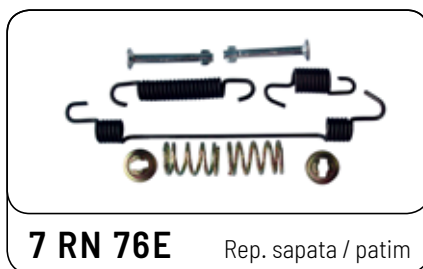

**7 RN 76E** Rep. sapata / patim



**7 TY 71** Rep. sapata / patim

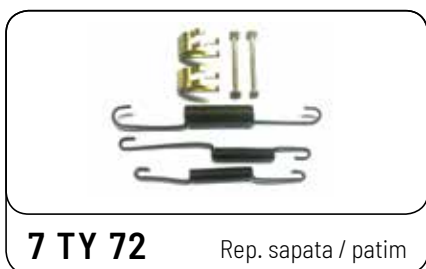

**7 TY 72** Rep. sapata / patim

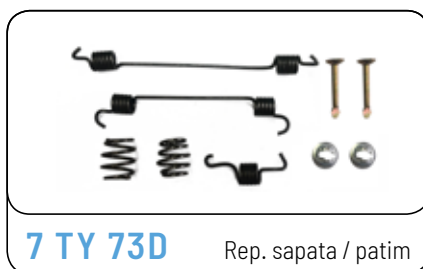

**7 TY 73D** Rep. sapata / patim

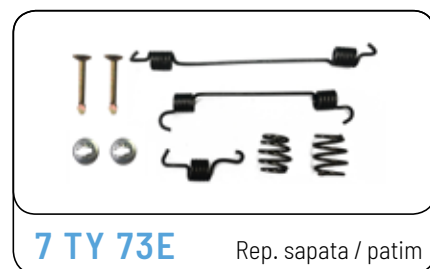

**7 TY 73E** Rep. sapata / patim



**7 VW 71** Rep. sapata / patim



**7 VW 72** Rep. sapata / patim

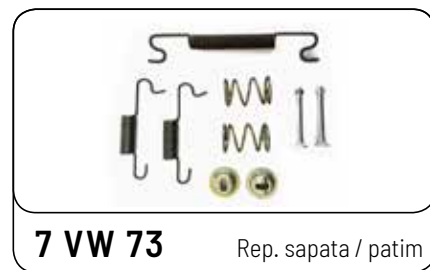

**7 VW 73** Rep. sapata / patim



**7 VW 74** Rep. sapata / patim



**7 VW 75** Rep. sapata / patim



**7 VW 76** Rep. sapata / patim



**7 VW 77** Rep. sapata / patim



**7 VW 78** Rep. sapata / patim



**7 VW 79** Rep. sapata / patim



**7 VW 80** Rep. sapata / patim



**7 VW 81** Rep. sapata / patim



**7 VW 82** Rep. sapata / patim

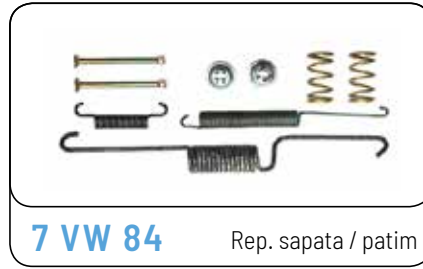

## reparos de pinça (parcial)



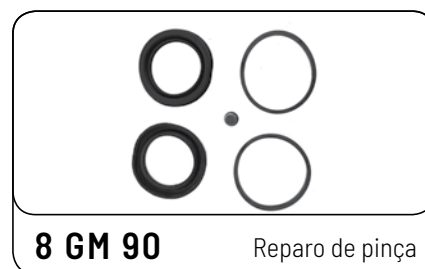
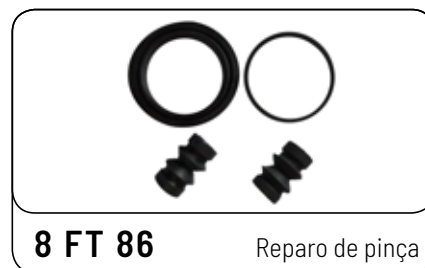
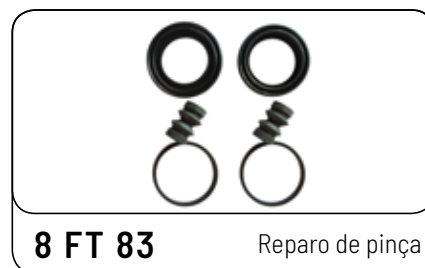

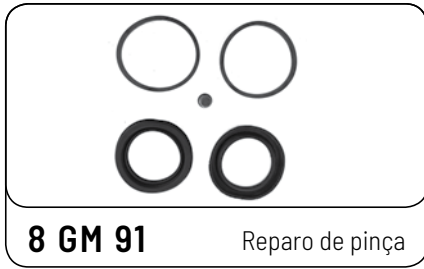

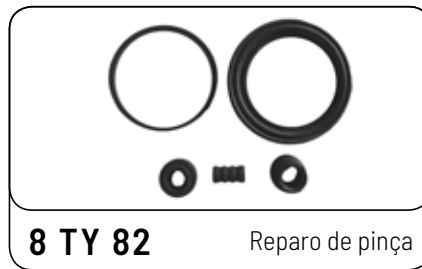

reparos de pinça (completo)









**9 GW 11** Reparo de pinça (compl.)



**9 GW 12** Reparo de pinça (compl.)



**9 LG 01** Reparo de pinça (compl.)



**9 LG 02** Reparo de pinça (compl.)



**9 LG 91** Reparo de pinça (compl.)



**9 LG 92** Reparo de pinça (compl.)



**9 LG 95** Reparo de pinça (compl.)



**9 MB 91** Reparo de pinça (compl.)



**9 VW 91** Reparo de pinça (compl.)



**9 VW 92** Reparo de pinça (compl.)



**9 VW 96** Reparo de pinça (compl.)



**9 VW 97** Reparo de pinça (compl.)



**9 VW 98** Reparo de pinça (compl.)



**9 VW 100** Reparo de pinça (compl.)

# REPAROS DE VEDAÇÃO DA PINÇA

CALIPER SEAL REPAIR KIT



REPUESTOS DE LAS GOMAS DEL CALIPER

## PRODUTOS E APLICAÇÕES

PRODUCTS AND APPLICATIONS



PRODUCTOS Y APLICACIONES





Reparo de vedação da pinça 40,50mm

Caliper seal repair kit 40,50mm  
Repuestos de las gomas del caliper 40,50mm

**10 RP 01**

MARCA/BRAND	VEÍCULO/VEHICLE	ANO/YEAR	RESTRIÇÃO/RESTRICTION
VOLKSWAGEN	FUSCA	1970 > 1996	SIST. VARGA



Reparo de vedação da pinça 48,00mm

Caliper seal repair kit 48,00mm  
Repuestos de las gomas del caliper 48,00mm

**10 RP 02**

MARCA/BRAND	VEÍCULO/VEHICLE	ANO/YEAR	RESTRIÇÃO/RESTRICTION
FORD	BELINA II	1983 > 1991	SIST. VARGA
FORD	DEL REY	1983 > 1991	SIST. VARGA
FORD	PAMPA	1983 > 1997	SIST. VARGA
GM - CHEVROLET	MONZA	1981 > 1987	
RENAULT	CLIO	2000 > ...	SIST. VARGA
RENAULT	SYMBOL	2009 > ...	
FIAT	ELBA	1986>1996	SIST. ATE
FIAT	FIORINO	1988>1993	SIST. ATE
FIAT	PREMIO	1985>1996	SIST. ATE
FIAT	UNO	1984>1998	SIST. ATE
GM-CHEVROLET	CELTA	2000>...	
GM-CHEVROLET	CORSA	1994>...	1.0/1.4
VOLKSWAGEN	GOLF	1996>1998	MOD.GL SIST.ATE (fabr.mexico)



Reparo de vedação da pinça 54,00mm

Caliper seal repair kit 54,00mm  
Repuestos de las gomas del caliper 54,00mm

**10 RP 03**

MARCA/BRAND	VEÍCULO/VEHICLE	ANO/YEAR	RESTRIÇÃO/RESTRICTION
ALFA ROMEO	145	1996 > 1999	SIST. ATE
FIAT	DOBLÒ	2002 > ...	
FIAT	FIORINO (mod. Uno)	1994 > ...	
FIAT	IDEA	2006 > ...	
FIAT	LINEA	2007 > ...	
FIAT	PALIO	1998 > ...	
FIAT	PALIO WEEKEND	1997 > 1998	MOTOR 1.6 16V

FIAT	PALIO WEEKEND	1998 > ...	
FIAT	PUNTO	2008 > ...	
FIAT	SIENA	1998 > ...	
FIAT	STRADA	1999 > ...	
FIAT	TEMPRA	1992 > 1999	
FIAT	TEMPRA SW	1994 > 1997	SIST. ATE
FIAT	TIPO	1993 > 1995	MOTOR 2.0 8V/16V
FIAT	TIPO	1996 > 1997	MOTOR 1.6 mpi
FIAT	UNO TURBO	1994 > 1996	
FORD	COURIER	1998 > ...	
FORD	ECOSPORT	2003 > 2012	
FORD	ESCORT	1983 > 1996	SIST. ATE
FORD	ESCORT HOBBY	1993 > 1996	
FORD	FIESTA	1996 > 2002	MOTOR 1.4/1.6
FORD	FIESTA	2003 > ...	MOTOR 1.6/1.0 SUPERCHARGER S/ABS
FORD	FIESTA SEDAN	2005 > ...	
FORD	FIESTA STREET HATCH	2002 > 2007	MOTOR 1.6
FORD	FIESTA STREET SEDAN	2002 > 2004	
FORD	KA	2008 > ...	MOTOR 1.6
FORD	ROYALE	1995 > 1996	SIST. ATE
FORD	VERONA	1990 > 1996	SIST. ATE
FORD	VERSAILLES	1995 > 1996	SIST. ATE
GM - CHEVROLET	ASTRA	1999 > 2011	MOTOR 1.8 8V S/ ABS C/DISCO 236mm
GM - CHEVROLET	MERIVA	2003 > 2012	
GM - CHEVROLET	OMEGA	1993 > 1998	MOTOR 4 CIL.
GM - CHEVROLET	SUPREMA	1993 > 1997	MOTOR 4 CIL.
GM - CHEVROLET	VECTRA	2002 > 2011	
GM - CHEVROLET	ZAFIRA	2002 > 2012	MOTOR 1.8/2.0 8V S/ABS
PEUGEOT	504 PICK-UP	1992 > 1999	SIST. ATE
VOLKSWAGEN	APOLLO	1990 > 1992	
VOLKSWAGEN	GOL (G2)	1995 > 2000	SIST. ATE C/MOTOR 2.0
VOLKSWAGEN	GOL (G2)	1995 > 2000	SIST. ATE C/ABS
VOLKSWAGEN	GOL (G3)	2000 > 2000	SIST. ATE C/ MOTOR 2.0
VOLKSWAGEN	GOL (G3)	2000 > 2000	SIST. ATE C/ABS
VOLKSWAGEN	GOL (G3)	2001 > 2005	SIST. ATE
VOLKSWAGEN	GOL (G4)	2006 > ...	SIST. ATE
VOLKSWAGEN	LOGUS	1993 > 1996	SIST. ATE
VOLKSWAGEN	PARATI (G2, G3 e G4)	1996 > 2012	SIST. ATE
VOLKSWAGEN	POINTER	1994 > 1996	SIST. ATE
VOLKSWAGEN	QUANTUM	1995 > 2002	SIST. ATE
VOLKSWAGEN	SANTANA	1995 > 2006	SIST. ATE
VOLKSWAGEN	SAVEIRO (G2, G3 e G4)	1998 > 2009	SIST. ATE



Reparo de vedação da pinça 48,00mm

Caliper seal repair kit 48,00mm  
Repuestos de las gomas del caliper 48,00mm

**10 RP 04**

MARCA/BRAND	VEÍCULO/VEHICLE	ANO/YEAR	RESTRIÇÃO/RESTRICTION
FIAT	147/SPAZIO	1976 > 1987	SIST. BENDIX
FIAT	FIORINO (mod. 147)	1978 > 1988	SIST. BENDIX
FIAT	OGGI	1983 > 1985	SIST. BENDIX
FIAT	PANORAMA	1980 > 1987	SIST. BENDIX
FORD	BELINA II	1978 > 1989	SIST. BENDIX COIFA C/ ENCAIXE INTERNO
FORD	CORCEL II	1978 > 1986	SIST. BENDIX COIFA C/ ENCAIXE INTERNO
FORD	DEL REY	1981 > 1989	SIST. BENDIX COIFA C/ ENCAIXE INTERNO
FORD	PAMPA	1982 > 1983	SIST. BENDIX COIFA C/ ENCAIXE INTERNO



Reparo de vedação da pinça 54,00mm

Caliper seal repair kit 54,00mm  
Repuestos de las gomas del caliper 54,00mm

**10 RP 05**

MARCA/BRAND	VEÍCULO/VEHICLE	ANO/YEAR	RESTRIÇÃO/RESTRICTION
GURGEL	G-15	1982 > 1984	
GURGEL	G-800 CS/CD	1983 > 1991	
GURGEL	X-15/CARAJÁS	1985 > 1993	
VOLKSWAGEN	KOMBI	1982 > ...	SIST. ATE



Reparo de vedação da pinça 48,00mm

Caliper seal repair kit 48,00mm  
Repuestos de las gomas del caliper 48,00mm

**10 RP 06**

MARCA/BRAND	VEÍCULO/VEHICLE	ANO/YEAR	RESTRIÇÃO/RESTRICTION
FIAT	147/SPAZIO	1981 > 1987	SIST. ATE (2 RODAS)
FIAT	FIORINO (mod. 147)	1981 > 1988	SIST. ATE (2 RODAS)
FIAT	OGGI	1983 > 1985	SIST. ATE (2 RODAS)
FIAT	PANORAMA	1981 > 1987	SIST. ATE (2 RODAS)
FIAT	UNO	1986 > 1988	SIST. ATE C/ DISCO 227mm (2 RODAS)
FORD	BELINA II	1981 > 1989	SIST. ATE (2 RODAS)
FORD	CORCEL II	1981 > 1986	SIST. ATE (2 RODAS)
FORD	DEL REY	1981 > 1989	SIST. ATE (2 RODAS)



Reparo de vedação da pinça 48,00mm

Caliper seal repair kit 48,00mm  
Repuestos de las gomas del caliper 48,00mm

**10 RP 07**

MARCA/BRAND	VEÍCULO/VEHICLE	ANO/YEAR	RESTRIÇÃO/RESTRICTION
CITROËN	XSARA	1998 > 2003	SIST. ATE
DAEWOO	LANOS	1997 > 2000	SIST. ATE C/ARO 13"
FIAT	DUNA	1994 > 1996	SIST. ATE
FIAT	ELBA	1986 > 1996	SIST. ATE
FIAT	FIORINO (mod. Uno)	1988 > 1993	SIST. ATE
FIAT	PALIO	1996 > 1998	
FIAT	PALIO WEEKEND	1997 > 1998	MOTOR 1.5
FIAT	PRÊMIO	1985 > 1996	SIST. ATE
FIAT	SIENA	1998 > 1998	
FIAT	UNO	1984 > ...	SIST. ATE C/ DISCO 240mm
FORD	FIESTA	1995 > 2002	MOTOR 1.0/1.3
FORD	FIESTA	2003 > ...	MOTOR 1.0
FORD	FIESTA STREET HATCH	2001 > 2007	MOTOR 1.0
FORD	KA	1997 > 2007	
FORD	KA	2008 > ...	MOTOR 1.0
FORD	ROYALE	1992 > 1994	
FORD	VERSAILLES	1991 > 1994	
PEUGEOT	106	1992 > 2001	SIST. ATE
PEUGEOT	205	1992 > 1998	SIST. ATE
PEUGEOT	306	1994 > 2002	SIST. ATE
SEAT	CORDOBA	1995 > 1999	
SEAT	IBIZA	1995 > 1999	
SEAT	IBIZA	2000 > 2002	MOTOR 1.0
VOLKSWAGEN	GOL (G1)	1984 > 1994	MOTOR 1.8/2.0
VOLKSWAGEN	GOL (G2)	1995 > 2005	SIST. ATE C/MOTOR 1.0/1.6/1.8 S/ABS
VOLKSWAGEN	GOL (G3)	2000 > 2000	SIST. ATE C/ MOTOR 1.0/1.6/1.8 S/ABS
VOLKSWAGEN	GOLF	1996 > 1998	MOD. GL SIST. ATE (fabr. México)
VOLKSWAGEN	PARATI (G1)	1987 > 1996	MOTOR 1.8
VOLKSWAGEN	PASSAT	1985 > 1989	MOTOR 1.8
VOLKSWAGEN	QUANTUM	1985 > 1994	
VOLKSWAGEN	SANTANA	1984 > 1994	
VOLKSWAGEN	SAVEIRO (G1)	1990 > 1997	MOTOR 1.8 SIST. ATE
VOLKSWAGEN	VOYAGE (G1)	1987 > 1994	MOTOR 1.8



Reparo de vedação da pinça 57,00mm

Caliper seal repair kit 57,00mm  
Repuestos de las gomas del caliper 57,00mm

**10 RP 08**

MARCA/BRAND	VEÍCULO/VEHICLE	ANO/YEAR	RESTRIÇÃO/RESTRICTION
mitsubishi	L200	1992 > 2006	L/GL/GLS
mitsubishi	L300	1995 > 1999	



Reparo de vedação da pinça 42,70mm

Caliper seal repair kit 42,70mm  
Repuestos de las gomas del caliper 42,70mm

**10 RP 09**

MARCA/BRAND	VEÍCULO/VEHICLE	ANO/YEAR	RESTRIÇÃO/RESTRICTION
toyota	HILUX PICK-UP	1999 > 2005	SIST. VARGA



Reparo de vedação da pinça 47,00mm

Caliper seal repair kit 47,00mm  
Repuestos de las gomas del caliper 47,00mm

**10 RP 10**

MARCA/BRAND	VEÍCULO/VEHICLE	ANO/YEAR	RESTRIÇÃO/RESTRICTION
GM - CHEVROLET	BLAZER	1996 > 2011	C/ TRAÇÃO 4X4
GM - CHEVROLET	S-10	1996 > 2012	C/ TRAÇÃO 4X4



Reparo de vedação da pinça 48,00mm

Caliper seal repair kit 48,00mm  
Repuestos de las gomas del caliper 48,00mm

**10 RP 11**

MARCA/BRAND	VEÍCULO/VEHICLE	ANO/YEAR	RESTRIÇÃO/RESTRICTION
FORD	BELINA	1969 > 1977	
FORD	BELINA II	1978 > 1989	SIST. BENDIX COIFA C/ ENCAIXE EXTERNO
FORD	CORCEL	1968 > 1977	



FORD	CORCEL II	1978 > 1986	SIST. BENDIX COIFA C/ ENCAIXE EXTERNO
FORD	DEL REY	1981 > 1989	SIST. BENDIX COIFA C/ ENCAIXE EXTERNO
FORD	PAMPA	1982 > 1983	SIST. BENDIX COIFA C/ ENCAIXE EXTERNO



Reparo de vedação da pinça 54,00mm

Caliper seal repair kit 54,00mm  
Repuestos de las gomas del caliper 54,00mm

**10 RP 12**

MARCA/BRAND	VEÍCULO/VEHICLE	ANO/YEAR	RESTRIÇÃO/RESTRICTION
GM - CHEVROLET	CARAVAN	1975 > 1992	SIST. VARGA
GM - CHEVROLET	OPALA	1971 > 1992	SIST. VARGA
PUMA	GTB	1974 > 1980	SIST. VARGA



Reparo de vedação da pinça 48,00mm

Caliper seal repair kit 48,00mm  
Repuestos de las gomas del caliper 48,00mm

**10 RP 13**

MARCA/BRAND	VEÍCULO/VEHICLE	ANO/YEAR	RESTRIÇÃO/RESTRICTION
GM - CHEVROLET	CHEVETTE	1973 > 1994	
GM - CHEVROLET	CHEVY	1983 > 1995	
GM - CHEVROLET	MARAJÓ	1981 > 1989	



Reparo de vedação da pinça 44,00mm

Caliper seal repair kit 44,00mm  
Repuestos de las gomas del caliper 44,00mm

**10 RP 14**

MARCA/BRAND	VEÍCULO/VEHICLE	ANO/YEAR	RESTRIÇÃO/RESTRICTION
GURGEL	BR-800/SUPERMINI	1989 > 1993	
VOLKSWAGEN	GOL (G1)	1980 > 1996	MOTOR 1.0/1.3/1.6
VOLKSWAGEN	GOL (G2)	1995 > 1995	SIST. ATE C/MOTOR 1.0/1.6 S/ABS
VOLKSWAGEN	PARATI (G1)	1983 > 1996	MOTOR 1.5/1.6
VOLKSWAGEN	PASSAT	1973 > 1989	MOTOR 1.5/1.6
VOLKSWAGEN	SAVEIRO (G1)	1982 > 1997	MOTOR 1.6
VOLKSWAGEN	VOYAGE (G1)	1982 > 1996	MOTOR 1.5/1.6



Reparo de vedação da pinça 40,00mm

Caliper seal repair kit 40,00mm  
Repuestos de las gomas del caliper 40,00mm

**10 RP 15**

MARCA/BRAND	VEÍCULO/VEHICLE	ANO/YEAR	RESTRIÇÃO/RESTRICTION
ALFA ROMEO	2300	1974 > 1986	
GURGEL	X-12/TOCANTINS	1981 > 1993	
GURGEL	XEF	1984 > 1986	
PUMA	GT/GTE/GTS	1974 > 1984	
VOLKSWAGEN	BRASILIA	1973 > 1982	
VOLKSWAGEN	FUSCA	1970 > 1996	SIST. ATE
VOLKSWAGEN	KARMANN GHIA TC	1970 > 1976	
VOLKSWAGEN	SEDAN 1600 4 PORTAS	1969 > 1971	
VOLKSWAGEN	TL	1969 > 1976	
VOLKSWAGEN	VARIANT	1970 > 1977	



Reparo de vedação da pinça 79,00mm

Caliper seal repair kit 79,00mm  
Repuestos de las gomas del caliper 79,00mm

**10 RP 16**

MARCA/BRAND	VEÍCULO/VEHICLE	ANO/YEAR	RESTRIÇÃO/RESTRICTION
FORD	F-100	1982 > 1987	(2 RODAS)
FORD	F-1000	1979 > 1994	C/ TRACÇÃO 4X2 (2 RODAS)
FORD	F-2000	1980 > 1987	(2 RODAS)
GM - CHEVROLET	A-10	1985 > 1989	(2 RODAS)
GM - CHEVROLET	A-20	1985 > 1992	(2 RODAS)
GM - CHEVROLET	BONANZA	1990 > 1992	(2 RODAS)
GM - CHEVROLET	C-10/14/15/16	1979 > 1989	(2 RODAS)
GM - CHEVROLET	C-20	1985 > 1992	(2 RODAS)
GM - CHEVROLET	D-10	1979 > 1984	(2 RODAS)
GM - CHEVROLET	D-20	1985 > 1992	(2 RODAS)
GM - CHEVROLET	VERANEIO	1979 > 1992	(2 RODAS)



Reparo de vedação da pinça 57,00mm

Caliper seal repair kit 57,00mm  
Repuestos de las gomas del caliper 57,00mm

**10 RP 17**

MARCA/BRAND	VEÍCULO/VEHICLE	ANO/YEAR	RESTRIÇÃO/RESTRICTION
ALFA ROMEO	2300	1974 > 1986	
FORD	GALAXIE	1969 > 1980	
FORD	MAVERICK	1977 > 1979	
GM - CHEVROLET	CARAVAN	1979 > 1991	SIST. ATE
GM - CHEVROLET	OPALA	1979 > 1991	SIST. ATE
PUMA	GTB	1979 > 1980	SIST. ATE



Reparo de vedação da pinça 66,00mm

Caliper seal repair kit 66,00mm  
Repuestos de las gomas del caliper 66,00mm

**10 RP 18**

MARCA/BRAND	VEÍCULO/VEHICLE	ANO/YEAR	RESTRIÇÃO/RESTRICTION
FORD	MAVERICK	1973 > 1976	



Reparo de vedação da pinça 44,00mm

Caliper seal repair kit 44,00mm  
Repuestos de las gomas del caliper 44,00mm

**10 RP 19**

MARCA/BRAND	VEÍCULO/VEHICLE	ANO/YEAR	RESTRIÇÃO/RESTRICTION
VOLKSWAGEN	VARIANT II	1978 > 1980	



Reparo de vedação da pinça 57,00mm

Caliper seal repair kit 57,00mm  
Repuestos de las gomas del caliper 57,00mm

**10 RP 20**

MARCA/BRAND	VEÍCULO/VEHICLE	ANO/YEAR	RESTRIÇÃO/RESTRICTION
GM - CAMINHÕES	D-40	1985 > 1997	
GMC	6-100	1998 > 2002	
GMC	6-150	1998 > 2002	



Reparo de vedação da pinça 54,00mm

Caliper seal repair kit 54,00mm  
Repuestos de las gomas del caliper 54,00mm

**10 RP 21**

MARCA/BRAND	VEÍCULO/VEHICLE	ANO/YEAR	RESTRICÇÃO/RESTRICTION
GM - CHEVROLET	IPANEMA	1990 > 1993	
GM - CHEVROLET	KADETT	1989 > 1993	
GM - CHEVROLET	MONZA	1988 > 1993	



Reparo de vedação da pinça 60,00mm

Caliper seal repair kit 60,00mm  
Repuestos de las gomas del caliper 60,00mm

**10 RP 22**

MARCA/BRAND	VEÍCULO/VEHICLE	ANO/YEAR	RESTRICÇÃO/RESTRICTION
MERCEDES BENZ - CAMINHÕES	L-709	1989 > 1996	
MERCEDES BENZ - CAMINHÕES	L-710	1996 > 2002	
MERCEDES BENZ - CAMINHÕES	LO-814	1996 > ...	
MERCEDES BENZ - CAMINHÕES	L/LO-912	1989 > ...	
MERCEDES BENZ - CAMINHÕES	L-914/914 E	1996 > ...	
MERCEDES BENZ - CAMINHÕES	L-1114	1996 > ...	



Reparo de vedação da pinça 76,00mm

Caliper seal repair kit 76,00mm  
Repuestos de las gomas del caliper 76,00mm

**10 RP 23**

MARCA/BRAND	VEÍCULO/VEHICLE	ANO/YEAR	RESTRICÇÃO/RESTRICTION
AGRALE	1600 A/D RS/RD	1990 > 1996	
AGRALE	1800 D RS/RD	1990 > 1996	
AGRALE	VOLARE A5/V5	2002 > ...	
AGRALE	VOLARE A6/V6	1998 > ...	
FORD - CAMINHÕES	F-4000	1985 > 1998	



Reparo de vedação da pinça 48,00mm

Caliper seal repair kit 48,00mm  
Repuestos de las gomas del caliper 48,00mm

**10 RP 24**

MARCA/BRAND	VEÍCULO/VEHICLE	ANO/YEAR	RESTRICÇÃO/RESTRICTION
FIAT	DUNA	1994 > 1996	SIST. VARGA
FIAT	ELBA	1986 > 1996	SIST. VARGA

FIAT	FIORINO (mod. Uno)	1988 > 1993	SIST. VARGA
FIAT	PRÊMIO	1985 > 1996	SIST. VARGA
FIAT	UNO	1984 > 1998	SIST. VARGA, BENDIX, WEBER E GIRLING
VOLKSWAGEN	GOLF	1996 > 1998	MOD. GL SIST. GIRLING (fabr. México)



Reparo de vedação da pinça 43,00mm

Caliper seal repair kit 43,00mm  
Repuestos de las gomas del caliper 43,00mm

**10 RP 25**

MARCA/BRAND	VEÍCULO/VEHICLE	ANO/YEAR	RESTRIÇÃO/RESTRICTION
GM - CHEVROLET	CARAVAN	1991 > 1992	
GM - CHEVROLET	OPALA	1991 > 1992	



Reparo de vedação da pinça 34,00mm

Caliper seal repair kit 34,00mm  
Repuestos de las gomas del caliper 34,00mm

**10 RP 26**

MARCA/BRAND	VEÍCULO/VEHICLE	ANO/YEAR	RESTRIÇÃO/RESTRICTION
ALFA ROMEO	145	1996 > 1999	
ALFA ROMEO	155	1995 > 1998	
ALFA ROMEO	SPIDER	1996 > 1998	
FIAT	COUPÉ	1995 > 1997	
FIAT	MAREA	1999 > 2007	
FIAT	MAREA WEEKEND	1999 > 2007	
FIAT	TEMPRA SW	1994 > 1997	
FIAT	TIPO	1993 > 1995	
GM - CHEVROLET	IPANEMA	1992 > 1993	
GM - CHEVROLET	KADETT	1992 > 1993	
GM - CHEVROLET	MONZA	1992 > 1993	



Reparo de vedação da pinça 57,00mm

Caliper seal repair kit 57,00mm  
Repuestos de las gomas del caliper 57,00mm

**10 RP 27**

MARCA/BRAND	VEÍCULO/VEHICLE	ANO/YEAR	RESTRIÇÃO/RESTRICTION
GM - CHEVROLET	OMEGA	1993 > 1998	MOTOR 6 CIL.
GM - CHEVROLET	SUPREMA	1993 > 1997	MOTOR 6 CIL.



Reparo de vedação da pinça 38,00mm

Caliper seal repair kit 38,00mm  
Repuestos de las gomas del caliper 38,00mm

**10 RP 28**

MARCA/BRAND	VEÍCULO/VEHICLE	ANO/YEAR	RESTRIÇÃO/RESTRICTION
GM - CHEVROLET	OMEGA	1993 > 1998	MOTOR 6 CIL.



Reparo de vedação da pinça 35,00mm

Caliper seal repair kit 35,00mm  
Repuestos de las gomas del caliper 35,00mm

**10 RP 29**

MARCA/BRAND	VEÍCULO/VEHICLE	ANO/YEAR	RESTRIÇÃO/RESTRICTION
GM - CHEVROLET	ASTRA	1999 > 2011	
GM - CHEVROLET	CALIBRA	1993 > 1995	
GM - CHEVROLET	MERIVA	2003 > 2012	
GM - CHEVROLET	OMEGA	1993 > 1998	MOTOR 4 CIL.
GM - CHEVROLET	VECTRA	1994 > 2011	
GM - CHEVROLET	ZAFIRA	2002 > 2012	
MERCEDES BENZ	CLASSE E	1995 > 2002	MOD. 280/320/420
MERCEDES BENZ	CLK	1998 > 2002	MOD. 320



Reparo de vedação da pinça 54,00mm

Caliper seal repair kit 54,00mm  
Repuestos de las gomas del caliper 54,00mm

**10 RP 30**

MARCA/BRAND	VEÍCULO/VEHICLE	ANO/YEAR	RESTRIÇÃO/RESTRICTION
FORD	F-1000	1993 > 1998	C/ TRAÇÃO 4X4
FORD	F-1000	1995 > 1998	C/ TRAÇÃO 4X2
GM - CHEVROLET	A-20	1993 > 1996	
GM - CHEVROLET	BONANZA	1993 > 1996	
GM - CHEVROLET	C-20	1993 > 1996	
GM - CHEVROLET	D-20	1993 > 1996	
GM - CHEVROLET	GRAND BLAZER	1998 > 2000	
GM - CHEVROLET	SILVERADO	1997 > 2001	
GM - CHEVROLET	VERANEIO	1993 > 1996	
GMC	3500 HD	1997 > 2002	



Reparo de vedação da pinça 60,00mm

Caliper seal repair kit 60,00mm  
Repuestos de las gomas del caliper 60,00mm

**10 RP 31**

MARCA/BRAND	VEÍCULO/VEHICLE	ANO/YEAR	RESTRIÇÃO/RESTRICTION
BMW	SÉRIE 3	1992 > 1999	MOD. M3
BMW	SÉRIE 5	1991 > 1995	
BMW	SÉRIE 5	1996 > 2003	MOD. 530/535/540/M5
BMW	SÉRIE 5 TOURING	1991 > 1997	
BMW	SÉRIE 5 TOURING	1997 > 2004	MOD. 530/540
BMW	SÉRIE 7	1991 > 1994	
BMW	SÉRIE 7	1994 > 2001	MOD. 740
BMW	SÉRIE 8	1990 > 1999	
BMW	X5	2000 > ...	E353
BMW	Z3	1997 > 2003	MOD. M 3.2
FORD	ESCORT	1993 > 1996	MOD. XR3
FORD	MONDEO	1994 > 2001	
FORD	MONDEO SW	1994 > 2001	
JAGUAR	XJ-6	1994 > 1997	
JAGUAR	XJ-12	1993 > 1997	
VOLKSWAGEN	POINTER	1994 > 1996	MOD. GTi



Reparo de vedação da pinça 33,00mm

Caliper seal repair kit 33,00mm  
Repuestos de las gomas del caliper 33,00mm

**10 RP 32**

MARCA/BRAND	VEÍCULO/VEHICLE	ANO/YEAR	RESTRIÇÃO/RESTRICTION
FORD	ESCORT	1993 > 1996	
KIA	SEPHIA	1993 > 2001	
VOLKSWAGEN	GOL (G2)	1995 > 2000	
VOLKSWAGEN	GOL (G3)	2000 > 2000	
VOLKSWAGEN	PARATI (G2, G3 e G4)	1996 > 2000	
VOLKSWAGEN	POINTER	1994 > 1996	



Reparo de vedação da pinça 66,00mm

Caliper seal repair kit 66,00mm  
Repuestos de las gomas del caliper 66,00mm

**10 RP 33**

MARCA/BRAND	VEÍCULO/VEHICLE	ANO/YEAR	RESTRIÇÃO/RESTRICTION
GM - CHEVROLET	BLAZER	1996 > 2011	C/ TRAÇÃO 4X2
GM - CHEVROLET	S-10	1995 > 2012	C/ TRAÇÃO 4X2
TOYOTA	BANDEIRANTE	1995 > 2001	



Reparo de vedação da pinça 38,00mm

Caliper seal repair kit 38,00mm  
Repuestos de las gomas del caliper 38,00mm

**10 RP 34**

MARCA/BRAND	VEÍCULO/VEHICLE	ANO/YEAR	RESTRICÇÃO/RESTRICTION
ALFA ROMEO	164	1991 > 1997	
AUDI	80	1993 > 1995	
AUDI	80 AVANT	1993 > 1996	
AUDI	100	1993 > 1995	
AUDI	100 AVANT	1994 > 1995	
AUDI	A6	1994 > 1997	
AUDI	A6 AVANT	1994 > 1997	
FIAT	TEMPRA	1993 > 1999	
PEUGEOT	405	1992 > 1995	
VOLKSWAGEN	GOLF	1994 > 1998	
VOLKSWAGEN	PASSAT	1991 > 1997	
VOLKSWAGEN	PASSAT VARIANT	1991 > 1997	
VOLVO	S40	1996 > 2003	SIST. GIRLING
VOLVO	V40	1997 > 2004	SIST. GIRLING



Reparo de vedação da pinça 48,00mm

Caliper seal repair kit 48,00mm  
Repuestos de las gomas del caliper 48,00mm

**10 RP 35**

MARCA/BRAND	VEÍCULO/VEHICLE	ANO/YEAR	RESTRICÇÃO/RESTRICTION
GM - CHEVROLET	CELTA	2001 > ...	
GM - CHEVROLET	CORSA	1994 > 2002	SIST. ATE
GM - CHEVROLET	CORSA CLASSIC	2003 > ...	SIST. ATE
GM - CHEVROLET	CORSA PICK-UP	1995 > 2003	SIST. ATE
GM - CHEVROLET	PRISMA	2007 > 2012	
GM - CHEVROLET	TIGRA	1998 > 1999	SIST. ATE



Reparo de vedação da pinça 38,00mm

Caliper seal repair kit 38,00mm  
Repuestos de las gomas del caliper 38,00mm

**10 RP 36**

MARCA/BRAND	VEÍCULO/VEHICLE	ANO/YEAR	RESTRICÇÃO/RESTRICTION
ALFA ROMEO	147	2003 > 2006	
ALFA ROMEO	156	1999 > 2003	



MARCA/BRAND	VEÍCULO/VEHICLE	ANO/YEAR	RESTRIÇÃO/RESTRICTION
ALFA ROMEO	156 SPORTWAGON	2001 > 2004	
ALFA ROMEO	159	2007 > 2009	
ALFA ROMEO	166	1999 > 2003	
AUDI	A3	1997 > ...	
AUDI	A3 SPORTBACK	2007 > ...	
AUDI	A4	1995 > 2008	
AUDI	A4 AVANT	1995 > 2008	
AUDI	A6	1998 > 2004	
AUDI	A6 AVANT	1998 > 2004	
AUDI	TT	1999 > ...	
CITROËN	C3	2002 > 2012	
CITROËN	C4	2004 > ...	SIST. TRW
CITROËN	C5	2008 > ...	SIST. TRW
CITROËN	C6	2006 > 2008	
CITROËN	C8	2003 > 2005	
PEUGEOT	307	2001 > 2012	SIST. TRW
PEUGEOT	407	2004 > 2009	
PEUGEOT	607	2000 > 2005	
PEUGEOT	807	2004 > 2005	
PEUGEOT	3008	2011 > ...	
RENAULT	GRAND SCENIC	2008 > 2009	
VOLKSWAGEN	CARAVELLE	1998 > 1999	
VOLKSWAGEN	EOS	2008 > 2012	
VOLKSWAGEN	EUROVAN	1998 > 1999	
VOLKSWAGEN	GOLF	1999 > ...	
VOLKSWAGEN	NEW BEETLE	2000 > 2010	
VOLKSWAGEN	PASSAT	1998 > 2005	
VOLKSWAGEN	PASSAT VARIANT	1998 > 2005	
VOLKSWAGEN	POLO	2002 > ...	
VOLVO	S40	1996 > 2003	SIST. LUCAS
VOLVO	V40	1997 > 2004	SIST. LUCAS



Reparo de vedação da pinça 54,00mm

Caliper seal repair kit 54,00mm  
Repuestos de las gomas del caliper 54,00mm

**10 RP 37**

MARCA/BRAND	VEÍCULO/VEHICLE	ANO/YEAR	RESTRIÇÃO/RESTRICTION
GM - CHEVROLET	IPANEMA	1994 > 1997	
GM - CHEVROLET	KADETT	1994 > 1997	
GM - CHEVROLET	MONZA	1994 > 1996	



Reparo de vedação da pinça 34,00mm

Caliper seal repair kit 34,00mm  
Repuestos de las gomas del caliper 34,00mm

**10RP38**

MARCA/BRAND	VEÍCULO/VEHICLE	ANO/YEAR	RESTRIÇÃO/RESTRICTION
GM - CHEVROLET	IPANEMA	1994 > 1998	
GM - CHEVROLET	KADETT	1994 > 1998	
GM - CHEVROLET	MONZA	1994 > 1996	



Reparo de vedação da pinça 54,00mm

Caliper seal repair kit 54,00mm  
Repuestos de las gomas del caliper 54,00mm

**10RP39**

MARCA/BRAND	VEÍCULO/VEHICLE	ANO/YEAR	RESTRIÇÃO/RESTRICTION
ALFA ROMEO	145	1996 > 1999	SIST. GIRLING
ALFA ROMEO	155	1995 > 1998	
ALFA ROMEO	164	1991 > 1997	
AUDI	80	1993 > 1995	MOTOR 2.0
AUDI	80 AVANT	1993 > 1996	MOTOR 2.0
AUDI	A4	1995 > 2000	SIST. GIRLING
AUDI	A4 AVANT	1995 > 2001	SIST. GIRLING
CITROËN	ZX	1992 > 1997	MOTOR 2,0 16V
FIAT	COUPÉ	1995 > 1997	
FIAT	TEMPRA SW	1994 > 1997	SIST. GIRLING/BENDIX
FIAT	TIPO	1993 > 1995	MOTOR 1.6 ie
MERCEDES BENZ	CLASSE C	1995 > 2000	MOD. 180/230
MERCEDES BENZ	CLASSE C TOURING	1996 > 2001	MOD. 180/200/230
PEUGEOT	306	1994 > 2002	SIST. LUCAS
PEUGEOT	405	1992 > 1999	MOTOR 2.0 SIST. LUCAS
RENAULT	MEGANE	1997 > 2005	
RENAULT	SCENIC	1999 > 2011	
SEAT	CORDOBA	2000 > 2002	
SEAT	CORDOBA VARIO	2000 > 2002	
SEAT	IBIZA	2000 > 2002	MOTOR 1.6
SEAT	INCA	1999 > 2002	
VOLKSWAGEN	GOLF	1994 > 1998	MOD. GLX/GTi
VOLKSWAGEN	GOLF	1995 > 1998	MOD. GL (fabr. Alemanha)
VOLKSWAGEN	PASSAT	1991 > 1997	MOTOR 2.0 4 CIL.
VOLKSWAGEN	PASSAT	1998 > 2005	MOTOR 1.8
VOLKSWAGEN	PASSAT VARIANT	1991 > 1997	MOTOR 2.0 4 CIL.
VOLKSWAGEN	PASSAT VARIANT	1998 > 2005	MOTOR 1.8
VOLKSWAGEN	POLO	2002 > ...	SIST. LUCAS
VOLKSWAGEN	POLO CLASSIC	1997 > 2002	
VOLKSWAGEN	VAN	1999 > 2002	
VOLVO	440	1992 > 1993	SIST. GIRLING
VOLVO	460	1992 > 1996	SIST. GIRLING



Reparo de vedação da pinça 48,00mm

Caliper seal repair kit 48,00mm  
Repuestos de las gomas del caliper 48,00mm

**10 RP 40**

MARCA/BRAND	VEÍCULO/VEHICLE	ANO/YEAR	RESTRIÇÃO/RESTRICTION
GM - CHEVROLET	CORSA	1997 > 2012	SIST. VARGA
GM - CHEVROLET	CORSA CLASSIC	2003 > ...	SIST. VARGA
GM - CHEVROLET	CORSA PICK-UP	1997 > 2003	SIST. VARGA
GM - CHEVROLET	MONTANA	2004 > ...	
VOLKSWAGEN	GOL (G2)	1997 > 2005	SIST. VARGA C/MOTOR 1.0/1.6/1.8 S/ABS
VOLKSWAGEN	GOL (G3)	2000 > 2000	SIST. VARGA C/ MOTOR 1.0/1.6/1.8 S/ABS
VOLKSWAGEN	SAVEIRO (G1)	1997 > 1997	MOTOR 1.8 SIST. VARGA



Reparo de vedação da pinça 52,00mm

Caliper seal repair kit 52,00mm  
Repuestos de las gomas del caliper 52,00mm

**10 RP 41**

MARCA/BRAND	VEÍCULO/VEHICLE	ANO/YEAR	RESTRIÇÃO/RESTRICTION
GM - CHEVROLET	ASTRA	1995 > 1996	
GM - CHEVROLET	CALIBRA	1993 > 1995	
GM - CHEVROLET	VECTRA	1994 > 1996	
GM - CHEVROLET	VECTRA	1997 > 2001	MOTOR 2.0/2.2 8V
HONDA	FIT	2003 > 2008	MOTOR 1.4



Reparo de vedação da pinça 57,00mm

Caliper seal repair kit 57,00mm  
Repuestos de las gomas del caliper 57,00mm

**10 RP 42**

MARCA/BRAND	VEÍCULO/VEHICLE	ANO/YEAR	RESTRIÇÃO/RESTRICTION
AUDI	100	1993 > 1995	
AUDI	100 AVANT	1994 > 1995	
AUDI	A4	1995 > 2008	SIST. ATE
AUDI	A4 AVANT	1995 > 2008	SIST. ATE
AUDI	A6	1994 > 2011	
AUDI	A6 AVANT	1994 > 2011	
GM - CHEVROLET	ASTRA	1999 > 2011	MOTOR 2.0 16V
GM - CHEVROLET	VECTRA	1997 > 2001	MOTOR 2.0/2.2 16V
GM - CHEVROLET	ZAFIRA	2002 > 2012	MOTOR 2.0 16V
KIA	CLARUS	1997 > 2000	
KIA	CLARUS WAGON	1998 > 2000	
MERCEDES BENZ	CLASSE C	1994 > 2000	MOD. 200/230K/240

MARCA/BRAND	VEÍCULO/VEHICLE	ANO/YEAR	RESTRIÇÃO/RESTRICTION
MERCEDES BENZ	CLASSE E	1995 > 2002	MOD. 200/200K/230/240/280/320/420
MERCEDES BENZ	CLASSE E TOURING	1996 > 2003	MOD. 200/200K/230/240/280/320
MERCEDES BENZ	CLK	1998 > 2002	MOD. 200K/230K/320
MERCEDES BENZ	SLK	2000 > 2004	MOD. 320/32 AMG
PEUGEOT	605	1992 > 2000	MOTOR 3.0 V6
SAAB	9000	1992 > 1993	
TROLLER	T4	2002 > ...	
VOLKSWAGEN	CARAVELLE	1998 > 1999	
VOLKSWAGEN	EUROVAN	1998 > 1999	
VOLKSWAGEN	PASSAT	1998 > 2005	MOTOR 1.8/1.8 TURBO/2.8 V6
VOLKSWAGEN	PASSAT VARIANT	1998 > 2005	MOTOR 1.8/1.8 TURBO/2.8 V6
VOLVO	850	1992 > 1997	
VOLVO	C70	1998 > 2005	
VOLVO	S70	1997 > 2000	
VOLVO	V70	1997 > 2000	



Reparo de vedação da pinça 54,00mm

Caliper seal repair kit 54,00mm  
Repuestos de las gomas del caliper 54,00mm

**10 RP 43**

MARCA/BRAND	VEÍCULO/VEHICLE	ANO/YEAR	RESTRIÇÃO/RESTRICTION
FORD	ROYALE	1995 > 1996	SIST. VARGA
FORD	VERSAILLES	1995 > 1996	SIST. VARGA
GM - CHEVROLET	IPANEMA	1997 > 1998	
GM - CHEVROLET	KADETT	1997 > 1998	
HONDA	CIVIC	1997 > 2000	SIST. VARGA
VOLKSWAGEN	GOL (G2)	1995 > 2000	SIST. VARGA C/MOTOR 2.0
VOLKSWAGEN	GOL (G2)	1995 > 2000	SIST. VARGA C/ABS
VOLKSWAGEN	GOL (G3)	2000 > 2000	SIST. VARGA C/ MOTOR 2.0
VOLKSWAGEN	GOL (G3)	2000 > 2000	SIST. VARGA C/ABS
VOLKSWAGEN	GOL (G3)	2001 > 2005	SIST. VARGA
VOLKSWAGEN	GOL (G4)	2006 > ...	SIST. VARGA
VOLKSWAGEN	PARATI (G2, G3 e G4)	1996 > 2012	SIST. VARGA
VOLKSWAGEN	QUANTUM	1995 > 2002	SIST. VARGA
VOLKSWAGEN	SANTANA	1995 > 2006	SIST. VARGA
VOLKSWAGEN	SAVEIRO (G2, G3 e G4)	1998 > 2009	SIST. VARGA



Reparo de vedação da pinça 54,00mm

Caliper seal repair kit 54,00mm  
Repuestos de las gomas del caliper 54,00mm

**10 RP 44**

MARCA/BRAND	VEÍCULO/VEHICLE	ANO/YEAR	RESTRIÇÃO/RESTRICTION
FORD	ESCORT	1993 > 2003	SIST. BOSCH
FORD	ESCORT SW	1997 > 2003	
FORD	VERONA	1994 > 1996	SIST. BOSCH
VOLKSWAGEN	LOGUS	1993 > 1996	SIST. BOSCH
VOLKSWAGEN	POINTER	1994 > 1996	SIST. BOSCH



Reparo de vedação da pinça 52,00mm

Caliper seal repair kit 52,00mm  
Repuestos de las gomas del caliper 52,00mm

**10 RP 45**

MARCA/BRAND	VEÍCULO/VEHICLE	ANO/YEAR	RESTRIÇÃO/RESTRICTION
MERCEDES BENZ	MB-180	1994 > 1996	



Reparo de vedação da pinça 44,00mm

Caliper seal repair kit 44,00mm  
Repuestos de las gomas del caliper 44,00mm

**10 RP 46**

MARCA/BRAND	VEÍCULO/VEHICLE	ANO/YEAR	RESTRIÇÃO/RESTRICTION
MERCEDES BENZ	SPRINTER	1997 > ...	



Reparo de vedação da pinça 60,50mm

Caliper seal repair kit 60,50mm  
Repuestos de las gomas del caliper 60,50mm

**10 RP 47**

MARCA/BRAND	VEÍCULO/VEHICLE	ANO/YEAR	RESTRIÇÃO/RESTRICTION
ASIA	TOPIC	1993 > 1999	



Reparo de vedação da pinça 51,00mm

Caliper seal repair kit 51,00mm  
Repuestos de las gomas del caliper 51,00mm

**10 RP 48**

MARCA/BRAND	VEÍCULO/VEHICLE	ANO/YEAR	RESTRIÇÃO/RESTRICTION
ASIA	TOWNER	1993 > 1999	



Reparo de vedação da pinça 54,00mm

Caliper seal repair kit 54,00mm  
Repuestos de las gomas del caliper 54,00mm

**10 RP 49**

MARCA/BRAND	VEÍCULO/VEHICLE	ANO/YEAR	RESTRIÇÃO/RESTRICTION
ALFA ROMEO	147	2003 > 2006	
ALFA ROMEO	156	1999 > 2003	
ALFA ROMEO	156 SPORTWAGON	2001 > 2004	
AUDI	A3	1997 > ...	
AUDI	A3 SPORTBACK	2007 > ...	
AUDI	TT	1999 > 2006	
BMW	SÉRIE 3	1991 > 2005	
BMW	Z3	1995 > 2003	
KIA	SEPHIA	1993 > 2001	
KIA	SHUMA	1998 > 2000	
PORSCHE	928	1992 > 1995	
VOLKSWAGEN	BORA	2001 > 2011	
VOLKSWAGEN	CROSSFOX	2005 > ...	
VOLKSWAGEN	EOS	2008 > 2012	
VOLKSWAGEN	FOX	2004 > ...	MOTOR 1.6
VOLKSWAGEN	FOX	2004 > ...	MOTOR 1.0 C/ DISCO 256x22mm
VOLKSWAGEN	GOLF	1999 > ...	
VOLKSWAGEN	NEW BEETLE	2000 > 2010	
VOLKSWAGEN	PASSAT	1991 > 1997	MOTOR 2.8 V6
VOLKSWAGEN	PASSAT VARIANT	1991 > 1997	MOTOR 2.8 V6
VOLKSWAGEN	SPACEFOX	2006 > ...	
VOLKSWAGEN	SPACE CROSS	2012 > ...	
VOLVO	440	1992 > 1993	SIST. ATE
VOLVO	460	1992 > 1996	SIST. ATE



Reparo de vedação da pinça 60,50mm

Caliper seal repair kit 60,50mm  
Repuestos de las gomas del caliper 60,50mm

**10 RP 50**

MARCA/BRAND	VEÍCULO/VEHICLE	ANO/YEAR	RESTRIÇÃO/RESTRICTION
KIA	BESTA	1993 > 1998	MOD. 2.2/2.7



Reparo de vedação da pinça 46,00mm

Caliper seal repair kit 46,00mm  
Repuestos de las gomas del caliper 46,00mm

**10 RP 51**

MARCA/BRAND	VEÍCULO/VEHICLE	ANO/YEAR	RESTRICÇÃO/RESTRICTION
KIA	BESTA	1998 > 2005	MOD. GS



Reparo de vedação da pinça 46,00mm

Caliper seal repair kit 46,00mm  
Repuestos de las gomas del caliper 46,00mm

**10 RP 52**

MARCA/BRAND	VEÍCULO/VEHICLE	ANO/YEAR	RESTRICÇÃO/RESTRICTION
AGRALE	MARRUÁ	2005 > ...	
FORD	EXPLORER	1995 > 2005	
FORD	RANGER	1995 > 2012	



Reparo de vedação da pinça 54,00mm

Caliper seal repair kit 54,00mm  
Repuestos de las gomas del caliper 54,00mm

**10 RP 53**

MARCA/BRAND	VEÍCULO/VEHICLE	ANO/YEAR	RESTRICÇÃO/RESTRICTION
VOLKSWAGEN	KOMBI	1997 > ...	SIST. VARGA



Reparo de vedação da pinça 54,00mm

Caliper seal repair kit 54,00mm  
Repuestos de las gomas del caliper 54,00mm

**10 RP 54**

MARCA/BRAND	VEÍCULO/VEHICLE	ANO/YEAR	RESTRICÇÃO/RESTRICTION
FORD	F-250	1999 > 2012	
FORD - CAMINHÕES	F-350	1999 > 2012	
FORD - CAMINHÕES	F-350	1999 > 2012	
FORD - CAMINHÕES	F-4000	1999 > 2012	
FORD - CAMINHÕES	F-4000	1999 > 2012	

# REPAROS DO PINO GUIA DA PINÇA

SLEEVE AND PIN GUIDE CLAMP



MANGA Y PASADOR DE GUIA DEL CALIPER

## PRODUTOS E APLICAÇÕES

PRODUCTS AND APPLICATIONS



PRODUCTOS Y APLICACIONES



Bucha e pino guia da pinça

Sleeve and pin guide clamp  
Manga y pasador de guia del caliper**10 RP 55**

MARCA/BRAND	VEÍCULO/VEHICLE	ANO/YEAR	RESTRIÇÃO/RESTRICTION
AUDI	A3	1999 > ...	
FIAT	147	01/76 > 12/87	
FIAT	BRAVA	01/99 > ...	2.0 8V
FIAT	BRAVA	01/99 > ...	1.8 8V
FIAT	BRAVO ABSOLUTE	07/12 > ...	1.8 16V
FIAT	BRAVO ESSENCE	07/12 > ...	1.8 16V
FIAT	DOBLO	01/01 > ...	
FIAT	ELBA	01/84 > ...	1.6 8V
FIAT	ELBA	01/84 > ...	1.5 8V
FIAT	FIORINO	01/92 > ...	1.5 8V
FIAT	FIORINO	01/84 > ...	1.5 8V
FIAT	FIORINO 147	01/77 > 12/87	
FIAT	MAREA	01/99 > ...	1.8 8V
FIAT	MAREA WEEKEND	01/99 > ...	1.8 8V
FIAT	OGGI	01/81 > 12/87	
FIAT	PALIO	04/96 > ...	1.0 8V
FIAT	PALIO	04/96 > ...	1.5 8V
FIAT	PALIO WEEKEND	04/96 > ...	1.6 16V
FIAT	PALIO WEEKEND	04/96 > ...	1.5 8V
FIAT	PALIO WEEKEND	04/96 > ...	1.6 8V
FIAT	PALIO WEEKEND	04/96 > ...	1.0 8V
FIAT	PANORAMA	01/81 > 12/87	
FIAT	SIENA	04/96 > ...	1.6 16V
FIAT	SIENA	04/96 > ...	1.5 8V
FIAT	SIENA	04/96 > ...	1.0 8V
FIAT	SIENA	04/96 > ...	1.6 8V
FIAT	SPAZIO	01/81 > 12/87	
FIAT	STRADA	04/96 > ...	1.6 8V
FIAT	STRADA	04/96 > ...	1.6 16V
FIAT	STRADA	04/96 > ...	1.5 8V
FIAT	TEMPRA	01/92 > ...	
FIAT	TIPO	01/94 > 12/97	2.0 8V



MARCA/BRAND	VEÍCULO/VEHICLE	ANO/YEAR	RESTRIÇÃO/RESTRICTION
FIAT	UNO	01/84 > ...	1.3 8V
FIAT	UNO	01/90 > ...	1.0 8V
FIAT	UNO	01/84 > ...	1.5 8V
FIAT	UNO	01/84 > ...	1.6 8V
FORD	ESCORT	01/97 > 12/03	1.8 16V
FORD	ESCORT	01/93 > 12/96	1.6 8V
FORD	ESCORT	01/93 > 12/96	1.8 8V
FORD	ROYALE	01/91 > 12/97	1.8 8V
FORD	VERONA	01/93 > 12/96	
FORD	VERSALLES	01/91 > 12/97	1.8 8V
FORD	VERSALLES	01/91 > 12/97	2.0 8V
GM - CHEVROLET	ASTRA	01/93 > 12/95	2.0 8V
GM - CHEVROLET	OMEGA	01/92 > 12/98	2.2 8V
GM - CHEVROLET	SUPREMA	01/92 > 12/98	2.2 8V
GM - CHEVROLET	VECTRA	01/93 > 12/95	2.0 8V
HONDA	FIT	04/12 > ...	1.4 16V
HONDA	FIT	04/12 > ...	1.5 16V
HONDA	FIT	04/03 > ...	1.4 8V
VOLKSWAGEN	APOLLO	01/90 > 12/92	
VOLKSWAGEN	FOX	10/03 > ...	1.6 8V
VOLKSWAGEN	GOL	01/84 > ...	1.8 8V
VOLKSWAGEN	GOL	01/84 > ...	1.6 8V
VOLKSWAGEN	GOLF	01/99 > ...	1.6 8V
VOLKSWAGEN	LOGUS	01/93 > 12/97	1.8 8V
VOLKSWAGEN	PARATI	01/87 > ...	1.8 8V
VOLKSWAGEN	PARATI	01/84 > ...	1.6 8V
VOLKSWAGEN	PASSAT	01/85 > 12/89	1.8 8V
VOLKSWAGEN	POINTER	01/93 > 12/97	1.8 8V
VOLKSWAGEN	QUANTUM	09/94 > ...	2.0 8V
VOLKSWAGEN	SANTANA	09/94 > ...	2.0 8V
VOLKSWAGEN	SAVEIRO	01/87 > ...	1.8 8V
VOLKSWAGEN	SAVEIRO	01/84 > ...	1.6 8V
VOLKSWAGEN	SPACE FOX	10/03 > ...	1.6 8V
VOLKSWAGEN	VOYAGE	01/88 > ...	1.8 8V
VOLKSWAGEN	VOYAGE	01/84 > ...	1.6 8V



Bucha e pino guia da pinça

Sleeve and pin guide clamp  
Manga y pasador de guia del caliper

**10 RP 56**

MARCA/BRAND	VEÍCULO/VEHICLE	ANO/YEAR	RESTRIÇÃO/RESTRICTION
AUDI	A3	01/99 > ...	1. 8T
FIAT	TIPO	01/94 > 12/97	2.0 16V
FORD	COURIER	01/97 > ...	1.3 8V
FORD	COURIER	01/99 > ...	1.6 8V
FORD	ECOSPORT	01/03 > ...	4X2 - 1.6 8V
FORD	ECOSPORT	01/03 > ...	4X2 - 1.4 TD
FORD	ECOSPORT	01/03 > ...	4X2 - 2.0 8V

MARCA/BRAND	VEÍCULO/VEHICLE	ANO/YEAR	RESTRIÇÃO/RESTRICTION
FORD	ECOSPORT	01/03 > ...	4X2 - SUPERCHARGER 1.0 SC
FORD	ECOSPORT	01/04 > ...	4X4 - 2.0 8V
FORD	ESCORT	01/89 > 12/92	1.8 8V
FORD	ESCORT	01/83 > 12/92	1.6 8V
FORD	ESCORT HOBBY	01/93 > 12/96	1.0 8V
FORD	ESCORT HOBBY	01/93 > 12/96	1.6 8V
FORD	ESCORT RACER	01/93 > 12/96	2.0 8V
FORD	ESCORT XR-3	01/93 > 12/96	2.0 8V
FORD	ESCORT XR-3	01/84 > 12/92	2.0 8V
FORD	FIESTA	05/96 > ...	1.0 8V
FORD	FIESTA	05/02 > ...	1.4 TD
FORD	FIESTA	05/02 > ...	1.6 8V
FORD	FIESTA	05/96 > ...	1.3 8V
FORD	FIESTA	05/02 > ...	1.0 8V
FORD	FIESTA	01/97 > ...	1.4 16V
FORD	FIESTA	05/02 > ...	1.0 SUPERCHARGER SC
FORD	FOCUS	07/02 > ...	2.0 8V
FORD	KA	05/96 > ...	1.0 8V
FORD	KA	05/96 > ...	1.3 8V
FORD	VERONA	01/89 > 12/92	
GM - CHEVROLET	ASTRA	01/98 > ...	1.8 8V
GM - CHEVROLET	ASTRA	01/98 > ...	2.0 8V
GM - CHEVROLET	CELTA	01/02 > ...	1.4 8V
GM - CHEVROLET	CELTA	01/02 > ...	1.0 8V
GM - CHEVROLET	CLASSIC	12/08 > ...	
GM - CHEVROLET	CORSA	01/94 > ...	1.0 16V
GM - CHEVROLET	CORSA	01/94 > ...	1.0 8V
GM - CHEVROLET	CORSA	01/94 > ...	1.6 8V
GM - CHEVROLET	CORSA	01/94 > ...	1.6 16V
GM - CHEVROLET	CORSA SEDAN	01/95 > ...	1.6 16V
GM - CHEVROLET	CORSA SEDAN	01/95 > ...	1.0 16V
GM - CHEVROLET	CORSA SEDAN	01/95 > ...	1.6 8V
GM - CHEVROLET	CORSA SEDAN	01/95 > ...	1.0 8V
GM - CHEVROLET	CORSA WAGON	01/95 > ...	1.0 8V
GM - CHEVROLET	CORSA WAGON	01/95 > ...	1.6 16V
GM - CHEVROLET	CORSA WAGON	01/95 > ...	1.0 16V
GM - CHEVROLET	CORSA WAGON	01/95 > ...	1.6 8V
GM - CHEVROLET	MERIVA	01/02 > ...	1.8 8V
GM - CHEVROLET	PICK-UP CORSA	01/95 > ...	1.6 8V
GM - CHEVROLET	VECTRA	01/96 > 10/01	8V
GM - CHEVROLET	VECTRA	11/01 > ...	16V
TROLLER	T4	10/01 > ...	TDI
VOLKSWAGEN	GOLF	01/99 > ...	1.8 TURBO
VOLKSWAGEN	LOGUS	01/94 > 12/97	2.0 8V
VOLKSWAGEN	POINTER	01/94 > 12/97	2.0 8V



Bucha e pino guia da pinça

Sleeve and pin guide clamp  
Manga y pasador de guia del caliper

**10 RP 57**

MARCA/BRAND	VEÍCULO/VEHICLE	ANO/YEAR	RESTRIÇÃO/RESTRICTION
GM - CHEVROLET	KADETT	1989 > ...	GS

MARCA/BRAND	VEÍCULO/VEHICLE	ANO/YEAR	RESTRIÇÃO/RESTRICTION
GM - CHEVROLET	KADETT	1989 > ...	SL
GM - CHEVROLET	KADETT	1989 > ...	SLE
GM - CHEVROLET	KADETT	1992 > 1993	GSI
GM - CHEVROLET	IPANEMA	1988 > 1993	
GM - CHEVROLET	MONZA	1988 > 1993	



Bucha e pino guia da pinça

Sleeve and pin guide clamp  
Manga y pasador de guia del caliper

**10 RP 58**

MARCA/BRAND	VEÍCULO/VEHICLE	ANO/YEAR	RESTRIÇÃO/RESTRICTION
GM - CHEVROLET	SUPREMA	1994 > 1998	4.1 L 12V
GM - CHEVROLET	SUPREMA	1993 > 1995	3.0 L 12V
GM - CHEVROLET	SUPREMA	1993 > 1997	2.0 L 8V
GM - CHEVROLET	SUPREMA	1994 > 1995	4.1 L 12V
GM - CHEVROLET	SUPREMA	1996 > 1998	2.2 L 8V
GM - CHEVROLET	SUPREMA	1996 > 1998	4.1 12V
FORD	ROYALE	1992 > 1997	1.8 L 8V
FORD	ROYALE	1992 > 1996	2.0 L 8V
FORD	VERSAILLES	1991 > 1997	1.8 L 8V
FORD	VERSAILLES	1991 > 1997	2.0 L 8V
TOYOTA	BANDEIRANTE	1993 > 2001	3.7 L 8V
VOLKSWAGEN	GOL	1994 > 1999	2.0 L 16V
VOLKSWAGEN	PARATI	1996 > 2001	2.0 L 16V
VOLKSWAGEN	QUANTUM	1989 > 2002	1.8 L 8V
VOLKSWAGEN	QUANTUM	1988 > 2002	2.0 L 8V
VOLKSWAGEN	SANTANA	1988 > 2006	2.0 L 8V
VOLKSWAGEN	SANTANA	1988 > 2006	1.8 L 8V



Bucha e pino guia da pinça

Sleeve and pin guide clamp  
Manga y pasador de guia del caliper

**10 RP 59**

MARCA/BRAND	VEÍCULO/VEHICLE	ANO/YEAR	RESTRIÇÃO/RESTRICTION
FORD	RANGER	1995 > 1997	
FORD	EXPLORER	1995 > 1998	



Bucha e pino guia da pinça 12mm

Sleeve and pin guide clamp 12mm  
Manga y pasador de guia del caliper 12mm

**10 RP 60**

MARCA/BRAND	VEÍCULO/VEHICLE	ANO/YEAR	RESTRIÇÃO/RESTRICTION
FORD	F-100	1969 > ...	
FORD	F-1000	1990 > 1993	
FORD	F-150	1996 > 2007	

MARCA/BRAND	VEÍCULO/VEHICLE	ANO/YEAR	RESTRIÇÃO/RESTRICTION
FORD	F-250	1998 > 2011	4x2
FORD	F-350	1998 > 2010	4x2
FORD	F-4000	1998 > 2010	



Bucha e pino guia da pinça 12,70mm

Sleeve and pin guide clamp 12,70mm  
Manga y pasador de guia del caliper 12,70mm

**10 RP 61**

MARCA/BRAND	VEÍCULO/VEHICLE	ANO/YEAR	RESTRIÇÃO/RESTRICTION
FORD	F-100	1969 > ...	
FORD	F-1000	1990 > 1993	
FORD	F-150	1996 > 2007	
FORD	F-250	1998 > 2011	4x2
FORD	F-350	1998 > 2010	4x2
FORD	F-4000	1998 > 2010	



Bucha e pino guia da pinça

Sleeve and pin guide clamp  
Manga y pasador de guia del caliper

**10 RP 62**

MARCA/BRAND	VEÍCULO/VEHICLE	ANO/YEAR	RESTRIÇÃO/RESTRICTION
VOLKSWAGEN	AMAROK	2010 > ...	



Bucha e pino guia da pinça

Sleeve and pin guide clamp  
Manga y pasador de guia del caliper

**10 RP 63**

MARCA/BRAND	VEÍCULO/VEHICLE	ANO/YEAR	RESTRIÇÃO/RESTRICTION
MITSUBISHI	L-200	1995 > ...	
MITSUBISHI	L-200 SAVANA	2004 > ...	
MITSUBISHI	L-200 OUTDOOR	2006 > ...	



Bucha e pino guia da pinça

Sleeve and pin guide clamp  
Manga y pasador de guia del caliper

**10 RP 64**

MARCA/BRAND	VEÍCULO/VEHICLE	ANO/YEAR	RESTRIÇÃO/RESTRICTION
MITSUBISHI	L-200 TRITON	2008 > ...	



Bucha e pino guia da pinça

Sleeve and pin guide clamp  
Manga y pasador de guia del caliper

**10 RP 65**

MARCA/BRAND	VEÍCULO/VEHICLE	ANO/YEAR	RESTRIÇÃO/RESTRICTION
GM - CHEVROLET	S10	2012 > ...	
GM - CHEVROLET	BLAZER	2012 > ...	



Bucha e pino guia da pinça

Sleeve and pin guide clamp  
Manga y pasador de guia del caliper

**10 RP 66**

MARCA/BRAND	VEÍCULO/VEHICLE	ANO/YEAR	RESTRIÇÃO/RESTRICTION
FORD	FUSION	2006 > ...	



Bucha e pino guia da pinça

Sleeve and pin guide clamp  
Manga y pasador de guia del caliper

**10 RP 67**

MARCA/BRAND	VEÍCULO/VEHICLE	ANO/YEAR	RESTRIÇÃO/RESTRICTION
FIAT	DUCATO	1998 > ...	



Bucha e pino guia da pinça

Sleeve and pin guide clamp  
Manga y pasador de guia del caliper

**10 RP 68**

MARCA/BRAND	VEÍCULO/VEHICLE	ANO/YEAR	RESTRIÇÃO/RESTRICTION
FORD	RANGER	2012 > ...	



Bucha e pino guia da pinça

Sleeve and pin guide clamp  
Manga y pasador de guia del caliper

**10 RP 69**

MARCA/BRAND	VEÍCULO/VEHICLE	ANO/YEAR	RESTRIÇÃO/RESTRICTION
HYUNDAI	HR	2006 > ...	



Bucha e pino guia da pinça

Sleeve and pin guide clamp  
Manga y pasador de guia del caliper

**10 RP 70**

MARCA/BRAND	VEÍCULO/VEHICLE	ANO/YEAR	RESTRIÇÃO/RESTRICTION
IVECO	DAILY	1998 > 2002	35.10
IVECO	DAILY	2008 > ...	35.S14
IVECO	DAILY	2011 > 2011	70C16
IVECO	DAILY	2011 > 2011	70C17
IVECO	DAILY	2008 > ...	35S14 ECOLINE
FIAT	DUCATO	2000 > ...	ARO 15
FIAT	DUCATO	2000 > ...	ARO 16
PEUGEOT	BOXER	2004 > ...	ARO 15
PEUGEOT	BOXER	2004 > ...	ARO 16



Bucha e pino guia da pinça

Sleeve and pin guide clamp  
Manga y pasador de guia del caliper

**10 RP 71**

MARCA/BRAND	VEÍCULO/VEHICLE	ANO/YEAR	RESTRIÇÃO/RESTRICTION
GM - CHEVROLET	D-20	1985 > ...	
GM - CHEVROLET	S-10	1995 > 2011	4X2, 4X4
GM - CHEVROLET	BLAZER	1995 > 2011	4X2, 4X4



Bucha e pino guia da pinça

Sleeve and pin guide clamp  
Manga y pasador de guia del caliper

**10 RP 72**

MARCA/BRAND	VEÍCULO/VEHICLE	ANO/YEAR	RESTRIÇÃO/RESTRICTION
GM - CHEVROLET	F-4000	1985 > 1998	4X2
AGRALE	VOLARE A5	1999 > 2002	
AGRALE	VOLARE A6/W6	1999 > ...	
AGRALE	VOLARE V5	2005 > ...	
AGRALE	VOLARE A8	1999 > 2010	



Bucha e pino guia da pinça

Sleeve and pin guide clamp  
Manga y pasador de guia del caliper

**10 RP 73**

MARCA/BRAND	VEÍCULO/VEHICLE	ANO/YEAR	RESTRIÇÃO/RESTRICTION
MERCEDES-BENZ	SPRINTER	1996 > ...	



Bucha e pino guia da pinça

Sleeve and pin guide clamp  
Manga y pasador de guia del caliper

**10 RP 74**

MARCA/BRAND	VEÍCULO/VEHICLE	ANO/YEAR	RESTRIÇÃO/RESTRICTION
RENAULT	MASTER	2001 > ...	2.5
RENAULT	MASTER	2001 > ...	2.8



Bucha e pino guia da pinça

Sleeve and pin guide clamp  
Manga y pasador de guia del caliper

**10 RP 75**

MARCA/BRAND	VEÍCULO/VEHICLE	ANO/YEAR	RESTRIÇÃO/RESTRICTION
FORD	F-1000	1994 > ...	COM DOIS PISTÕES



Bucha e pino guia da pinça

Sleeve and pin guide clamp  
Manga y pasador de guia del caliper

**10 RP 76**

MARCA/BRAND	VEÍCULO/VEHICLE	ANO/YEAR	RESTRIÇÃO/RESTRICTION
TOYOTA	COROLLA	2003 > 2008	



Pino guia da pinça

Pin guide clamp  
Pasador de guia del caliper

**10 RP 77**

MARCA/BRAND	VEÍCULO/VEHICLE	ANO/YEAR	RESTRIÇÃO/RESTRICTION
ASIA	TOPIC	1995 > ...	



Pino guia da pinça

Pin guide clamp  
Pasador de guia del caliper

**10 RP 78**

MARCA/BRAND	VEÍCULO/VEHICLE	ANO/YEAR	RESTRIÇÃO/RESTRICTION
KIA	BESTA	1993 > ...	



Bucha e pino guia da pinça

Sleeve and pin guide clamp  
Manga y pasador de guia del caliper

**10 RP 79**

MARCA/BRAND	VEÍCULO/VEHICLE	ANO/YEAR	RESTRIÇÃO/RESTRICTION
TOYOTA	COROLLA	2009 > 2014	

# Aplicações por veículos para aplicadores

## ASIA

VEICULO	RODA	DESCRIÇÃO	PRODUTO	PÁGINA
TOPIC ( TDS ) 1 RODA	DIANTEIRA	KIT DE FREIO A DISCO	1AS11	06
TOWNER 93/98	DIANTEIRA	REPARO DE PINCA	8AS81	45
TOPIC ( TDS ) 1 RODA	DIANTEIRA	REPARO DE PINCA	8AS82	45

## CITROËN

VEICULO	RODA	DESCRIÇÃO	PRODUTO	PRODUTO
C3 1.4 2002/... 1 RODA TRAS. (DIREITA)	TRASEIRA	REG.DE FREIO	4CI41D	22
C3 1.4 2002/... 1 RODA TRAS. (ESQUERDA)	TRASEIRA	REG.DE FREIO	4CI41E	22
JUMPER 96/... (AUT.) 1 RODA (DIREITA)	TRASEIRA	REG.DE FREIO	4CI42D	22
JUMPER 96/... (AUT.) 1 RODA (ESQUERDA)	TRASEIRA	REG.DE FREIO	4CI42E	22

## FIAT

VEICULO	RODA	DESCRIÇÃO	PRODUTO	PÁGINA
FIAT 147/- SPAZIO - OGGI - PAN	DIANTEIRA	KIT DE FREIO A DISCO	1FT11	07
FIAT 147-PANORAMA-SPAZIO 81/87	DIANTEIRA	KIT DE FREIO A DISCO	1FT12	07
UNO/PREMIO/PALIO/TEMPRA/TIPO	DIANTEIRA	KIT DE FREIO A DISCO	1FT13	07
FIAT 147-PANORAMA-SPAZIO 81/87	DIANTEIRA	KIT DE FREIO A DISCO	1FT14	07
IVECO DAILY - 1 RODA	DIANTEIRA	MOLA ANTI RUÍDO DA PASTILHA DE FREIO	1FT15	07
MARA / ALFA 145 / 155	DIANTEIRA	KIT DE FREIO A DISCO	1FT16	07
STILO 2009/...	DIANTEIRA	KIT DE FREIO A DISCO	1FT17	07
IDEA 2009/...	DIANTEIRA	KIT DE FREIO A DISCO	1FT18	08
PANORAMA SPAZIO 81/*87 FIAT 147 BELINA 4X4	DIANTEIRA	KIT FREIO A DISCO	1FT19	08
FIAT	TRASEIRA	REPAROS CENTR.DO PATIM	2FT21	13
TEMPRA / FIORINO 93/...	TRASEIRA	REPAROS CENTR.DO PATIM	2FT22	13
TIPO 1.6/PEUGEOT 206 SW/207 SW	TRASEIRA	REPAROS CENTR.DO PATIM	2FT23	13
PALIO	TRASEIRA	REPAROS CENTR.DO PATIM	2FT24	13
IVECO DAILY - 1 RODA	TRASEIRA	CENTRALIZADOR DE PATIM	2FT25	13
DUCATO	TRASEIRA	CENTRALIZADOR DE PATIM	2FT26	13
DUCATO TDS - PINO 32MM	TRASEIRA	CENTRALIZADOR DE PATIM	2FT27	13
DOBLÀ TDS	TRASEIRA	CENTRALIZADOR DE PATIM	2FT28	13
TORO	TRASEIRA	CENTRALIZADOR DE FREIO	2FT29	13
FIAT 147-PANORAMA-SPAZIO 81/87	TRASEIRA	REPAROS DA SAPATA	3FT31	17
UNO/ PREMIO	TRASEIRA	REPAROS DA SAPATA	3FT33	17
TEMPRA / FIORINO 93/... STRADA 1.4	TRASEIRA	REPAROS DA SAPATA	3FT34	18
TIPO 1.6	TRASEIRA	REPAROS DA SAPATA	3FT35	18
PALIO / SIENA	TRASEIRA	REPAROS DA SAPATA	3FT36	18
DOBLO TDS	TRASEIRA	REPARO DA SAPATA DE FREIO	3FT37	18
DUCATO .../01	TRASEIRA	REPARO DA SAPATA DE FREIO	3FT38	18
TORO	TRASEIRA	REPARO DA SAPATA DE FREIO	3FT41	18
FIAT 147-PANORAMA-SPAZIO 81/87	TRASEIRA	REG.DE FREIO	4FT41	26
TEMPRA 8V/STRADA/BRAVA/MAREA	TRASEIRA	REG.DE FREIO	4FT42D	26
TEMPRA 8V/STRADA/BRAVA/MAREA	TRASEIRA	REG.DE FREIO	4FT42E	26
TIPO 1.6 2.0 8V - PEUGEOT 206	TRASEIRA	REG.DE FREIO	4FT43D	26
TIPO 1.6 2.0 8V - PEUGEOT 206	TRASEIRA	REG.DE FREIO	4FT43E	26
PALIO	TRASEIRA	REG.DE FREIO	4FT44D	26
PALIO	TRASEIRA	REG.DE FREIO	4FT44E	26
DUCATO 94/02 - BOXER 98/...	TRASEIRA	REG.DE FREIO COMPLETO	4FT46D	26
DUCATTO 94/02 - BOXER 98/...	TRASEIRA	REG.DE FREIO COMPLETO	4FT46E	26
PALIO/WEEKEND/SIENA	TRASEIRA	REG.DE FREIO COMPLETO	4FT47D	26
PALIO/WEEKEND/SIENA	TRASEIRA	REG.DE FREIO COMPLETO	4FT47E	26
PALIO WEEKEND 09 / BRAVA / MAR	TRASEIRA	REGULADOR DE FREIO	4FT48	26
DUCATO 03/...	TRASEIRA	REGULADOR DE FREIO	4FT49	26
DOBLO LOCKER 2007/...	TRASEIRA	REGULADOR DE FREIO	4FT50	27



# Aplicações por veículos para aplicadores

PALIO 1.0 SISTEMA TEVES 1RODA TRAS. (DIR)	TRASEIRA	REGULADOR DE FREIO	4FT51D	27
PALIO 1.0 SISTEMA TEVES 1RODA TRAS. (ESQ)	TRASEIRA	REGULADOR DE FREIO	4FT51E	27
PALIO 2012/.. GRAND SIENA C ABC	TRASEIRA	REGULADOR FREIO	4FT53	27
PALIO WEEKEND FASE 3 08/12 ADVENTURE PALIO 1.0 2012	TRASEIRA	ACIONADOR	4FT54D	27
PALIO WEEKEND FASE 3 08/12 ADVENTURE PALIO 1.0 2012	TRASEIRA	ACIONADOR	4FT54E	27
TORO	TRASEIRA	REGULADOR DE FREIO	4FT55D	27
TORO	TRASEIRA	REGULADOR DE FREIO	4FT55E	27
TORO		ALAVANCA DA SAPATA	4FT56D	27
TORO		ALAVANCA DA SAPATA	4FT56E	27
ARGO 2017/CRONOS 2018		REGULADOR DE FREIO	4FT57D	27
ARGO 2017/CRONOS 2018		REGULADOR DE FREIO	4FT57E	27
FIAT (EMB.10 UNID.)		PINO TRAVA DA PASTILHA	5FT51	37
TEMPRA / FIORINO 93/...	DIANTEIRA E TRASEIRA	PARAFUSO SANGRADOR	6FT61	38
PALIO	DIANTEIRA E TRASEIRA	PARAFUSO SANGRADOR	6FT62	38
TORO	TRASEIRA	REP.SAPATA/PATIM	7FT70D	40
TORO	TRASEIRA	REP.SAPATA/PATIM	7FT70E	40
FIAT 147	TRASEIRA	REP.SAPATA/PATIM	7FT71	40
UNO/ PREMIO	TRASEIRA	REP.SAPATA/PATIM	7FT72	40
TEMPRA 91 até 92/ FIORINO 93/	TRASEIRA	REP.SAPATA/PATIM	7FT73D	40
TEMPRA / FIORINO 93/...	TRASEIRA	REP.SAPATA/PATIM	7FT73E	40
TIPO 1.6 /	TRASEIRA	REP.SAPATA/PATIM	7FT74D	40
TIPO 1.6 /	TRASEIRA	REP.SAPATA/PATIM	7FT74E	40
PALIO	TRASEIRA	REP.SAPATA/PATIM	7FT75D	40
PALIO	TRASEIRA	REP.SAPATA/PATIM	7FT75E	40
DOBLÀ TDS	TRASEIRA	CENTRALIZADOR / REP. DA SAPATA	7FT76	40
FIAT 147/- SPAZIO - OGGI - PAN		REPARO DE PINCA	8FT82	46
DUCATO BOXER / JUMPER 96/...		REPARO DE PINCA	8FT83	46
FIAT 147-PANORAMA-SPAZIO 81/87		REPARO DE PINCA	8FT84	46
DUCATO 1400 KG 94/02		REPARO DE PINCA	8FT85	46
STILO 02/...		REPARO DE PINCA	8FT86	46
STILO 02/...		REPARO DE PINCA	8FT87	46
FIAT 147/- SPAZIO - OGGI - PAN		REPARO DE PINCA	9FT91	49
FIAT 147-PANORAMA-SPAZIO 81/87		REPARO DE PINCA	9FT94	49

FORD				
VEICULO	RODA	DESCRIÇÃO	PRODUTO	PÁGINA
CORCEL/BELINA/DEL REY/FIAT 147	DIANTEIRA	KIT DE FREIO A DISCO	1FF11	
CORCEL/BELINA/DEL REY/FIAT 147	DIANTEIRA	KIT DE FREIO A DISCO	1FF12	
CORCEL / BELINA - 2 RODAS	DIANTEIRA	KIT DE FREIO A DISCO	1FO11	06
F100/F1000/F2000 - COMPLETO 2	DIANTEIRA	KIT DE FREIO A DISCO	1FO12	06
F100/F1000/F2000 SIST.BENDIX	DIANTEIRA	KIT DE FREIO A DISCO	1FO12E	06
ESCORT - VERONA 2 RODAS	DIANTEIRA	KIT DE FREIO A DISCO	1FO13	06
F4000	DIANTEIRA	KIT DE FREIO A DISCO	1FO14	06
CORCEL/BELINA/DEL REY 2 RODAS	DIANTEIRA	KIT DE FREIO A DISCO	1FO15	06
F4000	DIANTEIRA	KIT DE FREIO A DISCO	1FO16	06
ESCORT XR3 - 150MM 2 RODAS	DIANTEIRA	KIT DE FREIO A DISCO	1FO17	06
KA/FIESTA/COURIER - 2 RODAS	DIANTEIRA	KIT DE FREIO A DISCO	1FO18	06
FORD MONDEO - 2 RODAS	DIANTEIRA	KIT DE FREIO A DISCO	1FO19	06
CORCEL/BELINA/DEL REY 2 RODAS	DIANTEIRA	KIT DE FREIO A DISCO	1FO20	06
F250/F350/F4000 99/...	DIANTEIRA	KIT DE FREIO A DISCO	1FO21	06
F250 / F350	DIANTEIRA	KIT DE FREIO A DISCO	1FO22	06
FORD RANGER A PARTIR 11/97	DIANTEIRA	KIT DE FREIO A DISCO	1FO23	06

# Aplicações por veículos para aplicadores

FOCUS 00/...	TRASEIRA	MOLA TRAVA DA PASTILHA	1FO24	06
RANGER 94/97 - EXPLORER 95/...	DIANTEIRA	MOLA ANTIRUIDO	1FO25	07
FUSION A PARTIR 05/06	DIANTEIRA	MOLA ANTIRUIDO	1FO26	07
FUSION A PARTIR 05/06	DIANTEIRA	MOLA ANTIRUIDO DA PASTILHA FREIO	1FO27	07
F.250 98/... SOB MEDIDA	DIANTEIRA	KIT DE FREIO A DISCO F.250	1FO28	07
F.350 / 4000 98/... SOB MEDIDA	DIANTEIRA	KIT DE FREIO A DISCO	1FO29	07
RANGER 4X2 / 4X4	DIANTEIRA	REPARO DE FREIO A DISCO	1FO30	07
F1000 4X4	DIANTEIRA	REPARO FREIO DISCO	1FO31	07
F-1000 4X4 93/94 SISTEMA BENDIX 2 RODA	DIANTEIRA	ALINHADOR DE PASTILHA	1FO32	07
CORCEL/BELINA/DEL REY 81/89 2RODAS	DIANTEIRA	KIT DE FREIO A DISCO	1FO33	07
F-250 1998/2003 1 RODA	DIANTEIRA	ALINHADOR DE PASTILHA	1FO34	07
RANGER 2012/...FRONTIER 08/12...	DIANTEIRA	ALINHADOR DE PASTILHA	1FO35	07
ESCORT / FIAT	TRASEIRA	REPAROS CENTR.DO PATIM	2FF21	
F100 ATÉ 83	TRASEIRA	REPAROS CENTRALIZADOR DO PATIM	2FO21	12
F600/7000/11000	TRASEIRA	REPAROS CENTRALIZADO DO PATIM	2FO23	12
F350 56/F400/F4000 PINO 52MM(D	TRASEIRA	REPAROS CENTRALIZADOR DO PATIM	2FO24	12
WILLY	TRASEIRA	REPAROS CENTRALIZADOR DO PATIM	2FO28	12
CORCEL ( TDS)PINO 36MM	TRASEIRA	REPAROS CENTRALIZADOR DO PATIM	2FO29	12
ESCORT	TRASEIRA	REPAROS CENTRALIZADOR DO PATIM	2FO30	12
F1000 4X4	TRASEIRA	REPAROS CENTR.DO PATIM	2FO31	12
F4000	TRASEIRA	REPAROS CENTR.DO PATIM	2FO32	12
PAMPA 4X2	TRASEIRA	REPAROS CENTR.DO PATIM	2FO33	12
KA/FIESTA/COURIER - 2 RODAS	TRASEIRA	REPAROS CENTR.DO PATIM	2FO34	12
FORD MONDEO - 2 RODAS	TRASEIRA	REPAROS CENTR.DO PATIM	2FO35	12
F250 / F350	TRASEIRA	REPAROS CENTR.DO PATIM	2FO36	12
ECOSPORT / FIESTA	TRASEIRA	CENTRALIZADOR DE PATIM	2FO37	12
RANGER 11 POLEGADAS 98/...	TRASEIRA	CENTRALIZADOR DE PATIM	2FO39	12
ESCORT / VERONA 93/96	TRASEIRA	CENTRALIZADOR DE PATIM	2FO40	12
ECOSPORT / FIESTA 03/...LANTER	TRASEIRA	CENTRALIZADOR DE PATIM	2FO41	12
FOCUS	TRASEIRA	CENTRALIZADOR DE PATIM	2FO42	12
ESCORT 91/02	TRASEIRA	CENTRALIZADOR DE PATIM	2FO43	13
NEW FIESTA/NOVO KA 1.0/1.5 2014/...	TRASEIRA	CENTRALIZADOR DE FREIO	2FO44	13
CORCEL/BELINA/DEL REY 2 RODAS	TRASEIRA	REPAROS DA SAPATA	3FO31	16
BELINA 4X4/ PAMPA 4X4	TRASEIRA	REPAROS DA SAPATA	3FO33	16
CORCEL II/ BELINA II/ DEL REY/	TRASEIRA	REPAROS DA SAPATA	3FO35	16
F600/7000/11000	TRASEIRA	REPAROS DA SAPATA	3FO36	16
F100/1000 SIST.BENDIX	TRASEIRA	REPAROS DA SAPATA	3FO39	16
F400/ 2000/ 4000	TRASEIRA	REPAROS DA SAPATA	3FO40	17
F350/400/4000	TRASEIRA	REPAROS DA SAPATA	3FO43	17
PAMPA 4X2	TRASEIRA	REPAROS DA SAPATA	3FO44	17
ESCORT	TRASEIRA	REPAROS DA SAPATA	3FO45	17
CORCEL II/ BELINA II/ DEL REY/	TRASEIRA	REPAROS DA SAPATA	3FO46	17
F600/7000/11000	TRASEIRA	REPAROS DA SAPATA	3FO47	17
KA/FIESTA/COURIER - 2 RODAS	TRASEIRA	REPAROS DA SAPATA	3FO48	17
FORD MONDEO - 2 RODAS	TRASEIRA	REPAROS DA SAPATA	3FO49	17
F250 / F350	TRASEIRA	REPAROS DA SAPATA	3FO50	17
F7000 / CARGO	TRASEIRA	REPAROS DA SAPATA	3FO51	17
RANGER 10 POLEGADAS 98/...	TRASEIRA	REPARO DA SAPATA	3FO52	17
RANGER 11 POLEGADAS 98/...	TRASEIRA	REPARO DA SAPATA	3FO53	17
ECOSPORT / FIESTA	TRASEIRA	REPARO DA SAPATA	3FO55	17
RANGER 11 POLEGADAS 98/...	TRASEIRA	REPARO DA SAPATA DE FREIO	3FO57	17
ESCORT / VERONA 93/96	TRASEIRA	REPARO DA SAPATA DE FREIO	3FO59	17
FOCUS	TRASEIRA	REPARO DA SAPATA DE FREIO	3FO60	17
ESCORT 91/02	TRASEIRA	REPARO DA SAPATA DE FREIO	3FO61	17

# Aplicações por veículos para aplicadores

F1000/F4000	TRASEIRA	PINO DO CILINDRO	4FO41	23
F600/7000/11000	TRASEIRA	PINO DO CILINDRO	4FO42	23
F600/7000/11000	TRASEIRA	PINO DE PATINS	4FO43	23
F100/1000	TRASEIRA	PINO ANCORA	4FO44	23
F600/11000	TRASEIRA	REG.DE FREIO	4FO45D	23
F600/11000	TRASEIRA	REG.DE FREIO	4FO45E	23
F100/1000	TRASEIRA	REG.DE FREIO	4FO46	23
F100/F1000 - AUTOMATICO	TRASEIRA	REG.AUTOMATICO 7/16"	4FO46D	23
F100/F1000 - AUTOMATICO	TRASEIRA	REG. AUTOMATICO 7/16"	4FO46E	23
F4000	TRASEIRA	REG.DE FREIO	4FO47	23
CORCEL II/ BELINA II/ DEL REY/	TRASEIRA	REG. DE FREIO	4FO48D	23
CORCEL II/ BELINA II/ DEL REY/	TRASEIRA	REG.DE FREIO	4FO48E	23
PAMPA	TRASEIRA	REG.DE FREIO	4FO49D	23
PAMPA	TRASEIRA	REG.DE FREIO	4FO49E	23
F600/11000	TRASEIRA	PINO CILINDRO DE FREIO	4FO50	23
F350/400/2000/4000	TRASEIRA	ALAV.DA SAPATA DE FREIO	4FO51D	24
F350/400/2000/4000	TRASEIRA	ALAV.DA SAPATA DE FREIO	4FO51E	24
F350/400/2000/4000	TRASEIRA	HASTE DO FREIO-DE-MAO	4FO52	24
CORCEL II/ BELINA II/ DEL REY/	TRASEIRA	REG.DE FREIO	4FO53D	24
CORCEL II/ BELINA II/ DEL REY/	TRASEIRA	REG.DE FREIO	4FO53E	24
PAMPA	TRASEIRA	REG.DE FREIO	4FO54D	24
PAMPA	TRASEIRA	REG.DE FREIO	4FO54E	24
F100/150 - AUTOMATICO	TRASEIRA	JG DE REG.AUTOMATICA	4FO55D	24
F100/150 - AUTOMATICO	TRASEIRA	JG DE REG.AUTOMATICA	4FO55E	24
F250/350 - AUTOMATICO	TRASEIRA	JG DE REG.AUTOMATICA	4FO56D	24
F250/350 - AUTOMATICO	TRASEIRA	JG DE REG.AUTOMATICA	4FO56E	24
F250/350 - AUTOMATICO	TRASEIRA	REG.DE FREIO	4FO57D	24
F250/350 - AUTOMATICO	TRASEIRA	REG.DE FREIO	4FO57E	24
F100/1000	TRASEIRA	ALAVANCA DA SAPATA	4FO58D	24
F100/1000	TRASEIRA	ALAVANCA DA SAPATA	4FO58E	24
F100 ATÉ83	TRASEIRA	HASTE DE AC.DAS SAPATAS	4FO59	24
F1000 4X4	TRASEIRA	HASTE DE AC.DAS SAPATAS	4FO60	25
CORCEL II/ BELINA II/ DEL REY/	TRASEIRA	REG.DE FREIO	4FO61D	25
CORCEL II/ BELINA II/ DEL REY/	TRASEIRA	REG.DE FREIO	4FO61E	25
FORD RANGER / DAKOTA	TRASEIRA	REG.DE FREIO AUTOMATICO	4FO62D	25
FORD RANGER / DAKOTA	TRASEIRA	REG.DE FREIO AUTOMATICO	4FO62E	25
PICK-UP - COURRIER 97/	TRASEIRA	CONJ. DE ALAVANCAS DE FREIO	4FO63	25
RANGER 9 POLEGADAS	TRASEIRA	JOGO DE REGULAGEM AUTOMATICA	4FO63D	25
RANGER 9 POLEGADAS	TRASEIRA	JOGO DE REGULAGEM AUTOMATICA	4FO63E	25
RANGER 10 POLEGADAS 95/...	TRASEIRA	JOGO DE REGULAGEM AUTOMATICA	4FO64D	25
RANGER 10 POLEGADAS 95/...	TRASEIRA	JOGO DE REGULAGEM AUTOMATICA	4FO64E	25
RANGER 11 POLEGADAS 98/...	TRASEIRA	JOGO DE REGULAGEM AUTOMATICA	4FO65D	25
RANGER 11 POLEGADAS 98/...	TRASEIRA	JOGO DE REGULAGEM AUTOMATICA	4FO65E	25
F.2000 / F.4000	TRASEIRA	KIT ACIONADOR DO FREIO AUTOMATICO	4FO66D	25
F.2000 / F.4000	TRASEIRA	KIT ACIONADOR DO FREIO AUTOMATICO	4FO66E	25
ECOSPORT / FIESTA 03/...	TRASEIRA	REGULADOR DE FREIO AUTOMÁTICO	4FO67D	25
ECOSPORT / FIESTA 03/...	TRASEIRA	REGULADOR DE FREIO AUTOMÁTICO	4FO67E	25
COURIER	TRASEIRA	REGULADOR DE FREIO AUTOMÁTICO	4FO68D	25
COURIER	TRASEIRA	REGULADOR DE FREIO AUTOMÁTICO	4FO68E	25
ESCORT 2012	TRASEIRA	REGULADOR DE FREIO	4FO70	25
NEW FIESTA/NOVO KA 1.0/1.5 2014/...	TRASEIRA	REGULADOR DE FREIO	4FO71D	25
NEW FIESTA/NOVO KA 1.0/1.5 2014/...	TRASEIRA	REGULADOR DE FREIO	4FO71E	25
RANGER 2012/... FRONTIER 08/12... PATHFINDER 96	TRASEIRA	ALAVANCA DA SAPATA	4FO72D	25
RANGER 2012/... FRONTIER 08/12... PATHFINDER 96	TRASEIRA	ALAVANCA DA SAPATA	4FO72E	25

# Aplicações por veículos para aplicadores

CORCEL (EMB.10 UNID.)		PINO TRAVA DA PASTILHA	5FO51	37
F4000 (EMB.10 UNID.)		PINO TRAVA DA PASTILHA	5FO52	37
ESCORT	DIANTEIRA	PARAFUSO SANGRADOR	6FO61	38
F100 ATÉ 83	TRASEIRA	REP.SAPATA/PATIM	7FO71	39
F1000 4X4	TRASEIRA	REP.SAPATA/PATIM	7FO72	39
F4000	TRASEIRA	REP.SAPATA/PATIM	7FO73	39
F350/400/4000	TRASEIRA	REP.SAPATA/PATIM	7FO74	39
CORCEL II/ BELINA II/ DEL REY/	TRASEIRA	REP.SAPATA/PATIM	7FO75D	39
CORCEL II/ BELINA II/ DEL REY/	TRASEIRA	REP.SAPATA/PATIM	7FO75E	39
CORCEL II/ BELINA II/ DEL REY/	TRASEIRA	REP.SAPATA/PATIM	7FO76D	39
CORCEL II/ BELINA II/ DEL REY/	TRASEIRA	REP.SAPATA/PATIM	7FO76E	39
ESCORT	TRASEIRA	REP.SAPATA/PATIM	7FO77D	39
ESCORT	TRASEIRA	REP.SAPATA/PATIM	7FO77E	39
PAMPA 4X2	TRASEIRA	REP.SAPATA/PATIM	7FO78D	39
PAMPA 4X2	TRASEIRA	REP.SAPATA/PATIM	7FO78E	40
KA/FIESTA/COURIER - 2 RODAS	TRASEIRA	REP.SAPATA/PATIM	7FO79D	40
KA/FIESTA/COURIER - 2 RODAS	TRASEIRA	REP.SAPATA/PATIM	7FO79E	40
FORD MONDEO - 2 RODAS	TRASEIRA	REP.SAPATA/PATIM	7FO80D	40
FORD MONDEO - 2 RODAS	TRASEIRA	REP.SAPATA/PATIM	7FO80E	40
F250 / F350	TRASEIRA	REP.SAPATA/PATIM	7FO81	40
RANGER II POLEGADAS 98/...	TRASEIRA	CENTRALIZADOR / REP. DA SAPATA	7FO83	40
ESCORT / VERONA 93/96	TRASEIRA	CENTRALIZADOR / REP. DA SAPATA	7FO84D	40
ESCORT / VERONA 93/96	TRASEIRA	CENTRALIZADOR / REP. DA SAPATA	7FO84E	40
ECOSPORT / FIESTA 03/...	TRASEIRA	CENTRALIZADOR / REP. DA SAPATA	7FO85	40
FOCUS	TRASEIRA	CENTRALIZADOR / REP. DA SAPATA	7FO86D	40
FOCUS	TRASEIRA	CENTRALIZADOR / REP. DA SAPATA	7FO86E	40
ESCORT 91/02	TRASEIRA	CENTRALIZADOR / REP. DA SAPATA	7FO87D	40
ESCORT 91/02	TRASEIRA	CENTRALIZADOR / REP. DA SAPATA	7FO87E	40
NEW FIESTA/NOVO KA 1.0/1.5 2014/...	TRASEIRA	REPARO DA SAPATA/PATIM	7FO88	40
TIPO 2.0 16V 94/97/ ECO SPORT		REPARO DE PINCA	8FF83	45
UNO 84/.../PREMIO 84/.../DEL R		REPARO DE PINCA	8FF85	45
BELINA/ CORCEL II - 77/86,		REP.DA RODA FREIO A DISCO	8FO82	45
FIESTA 1.0 02/...		REPARO DE PINCA	8FO83	45
ESCORT XR3 93/96 ARGENTINO		REPARO DE PINCA	8FO84	45
KA/FIESTA/COURIER - 2 RODAS		REPARO DE PINCA	8FO85	45
EXPLORER / RANGER 93/95		REPARO DE PINCA	8FO86	45
BELINA II 78/89/CORCEL II 78/8		REPARO DE PINCA	8FO87	45
F4000 85/98		REPARO DE PINCA	8FO88	46
RANGER EXPLORER 95/...		REPARO DE PINCA	8FO89	46
F 4000 85/... VOLARE 98/...		REPARO DE PINCA	8FO90	46
F 250 / 350 / 4000 99/...		REPARO DE PINCA	8FO91	46
FIESTA 1.0 02/...		REPARO DE PINCA	9FO91	49
ESCORT XR3 93/96 ARGENTINO		REPARO DE PINCA	9FO93	49
FIESTA/KA 1.0/1.3 96/COURIER/9		REPARO DE PINCA	9FO95	49
BELINA II 78/89/CORCEL II 78/8		REPARO DE PINCA	9FO97	49
F4000 85/98		REPARO DE PINCA	9FO98	49
TIPO 2.0 /ESCORT 83/92/VERONA		REPARO DE PINCA	9FF91	48
UNO 84/.../PREMIO 84/.../DEL R		REPARO DE PINCA	9FF95	48

## FORD / GM

VEICULO	RODA	DESCRIÇÃO	PRODUTO	PÁGINA
F100/F1000/F2000 A/C/D-10-C14	DIANTEIRA	KIT DE FREIO A DISCO	1FG11	06
ACD 13/20- 93/II - ACD 13/20 A	DIANTEIRA	KIT DE FREIO A DISCO	1FG12	06

# Aplicações por veículos para aplicadores

A/C/D 20 93/... SILVERADO	DIANTEIRA	KIT DE FREIO A DISCO	1FG13	06
F1000 - 4X4 A/C/D-10 - C14	DIANTEIRA	KIT DE FREIO DISCO	1FG14	06
OPALA/CARAVAN/PAMPA/BELINA 4X4	TRASEIRA	REG.DE FREIO	4FG53D	22
OPALA/CARAVAN/PAMPA/BELINA 4X4	TRASEIRA	REG.DE FREIO	4FG53E	22
F4000 - A/C/D 40 85/	TRASEIRA	REG.DE FREIO AUTOMATICO	4FG54D	22
F4000 - A/C/D 40 85/	TRASEIRA	REG.DE FREIO AUTOMATICO	4FG54E	22
F250/350/ A/C/D-20	TRASEIRA	REG.DE FREIO MAN.- SIST.BENDIX	4FG56D	22
F250/350/ A/C/D-20	TRASEIRA	REG.DE FREIO MAN.- SIST.BENDIX	4FG56E	22
F400/F2000/F4000-ACD 40	TRASEIRA	JOGO DE REG.AUTOMATICA	4FG57D	23
F400/F2000/F4000-ACD 40	TRASEIRA	JOGO DE REG.AUTOMATICA	4FG57E	23
F250/350/ A/C/D-20	TRASEIRA	REP.DO FREIO TRASEIRO - SIST.BENDIX	4FG58	23
CAMINHÇO FORD/GM 7/16X20	DIANTEIRA E TRAS.	PARAFUSO SANGRADOR	6FG61	37
D - 10/20/40-OPALA-F1000	DIANTEIRA E TRAS.	PARAFUSO SANGRADOR	6FG62	37
CHEVETTE/CORCEL/BELINA - M7X1	DIANTEIRA E TRAS.	PARAFUSO SANGRADOR	6FG63	37
MZA 82/KADETT -IPANEMA 89/PAMP		REPARO DE PINCA	8FG10	45
GALAXIE / MAVERICK/OPALA/CARAV		REPARO DE PINCA	8FG82	45
F100/F1000/F2000 A/C/D-10-C14		REPARO DE PINCA	8FG83	45
MONZA 82/KADETT/IPANEMA89/(D)		REPARO DE PINCA	9FG10	48
OPALA/CARAVAN 79/		REPARO DE PINCA	9FG92	49
F100/F1000/F2000 A/C/D-10-C14		REPARO DE PINCA	9FG93	49

## GENERAL MOTORS

VEICULO	RODA	DESCRIÇÃO	PRODUTO	PÁGINA
A/C/D-10-C14-D20-VERANEIO-BONA	DIANTEIRA	KIT DE FREIO A DISCO	1GM11	08
A/C/D-10-C14-D20-VERANEIO-BONA	DIANTEIRA	KIT DE FREIO A DISCO	1GM11E	08
CHEVETTE / CHEVY 500	DIANTEIRA	KIT DE FREIO A DISCO	1GM12	08
OPALA/CARAVAN 79/	DIANTEIRA	KIT DE FREIO A DISCO	1GM13	08
CORSA/TIGRA	TRASEIRA	KIT DE FREIO A DISCO	1GM14	08
VCT(94/96)/OMEGA/SUPREMA-(D)	DIANTEIRA	KIT DE FREIO A DISCO	1GM15	08
VECTRA/ASTRA(T)	DIANTEIRA	KIT DE FREIO A DISCO	1GM16	08
OMEGA/SUPREMA	DIANTEIRA	KIT DE FREIO A DISCO	1GM17	08
CHEVETTE / CHEVY 500	DIANTEIRA	KIT DE FREIO A DISCO	1GM18	08
OPALA/CARAVAN 79	DIANTEIRA	KIT DE FREIO A DISCO	1GM19	08
VECTRA/ASTRA(T)	DIANTEIRA	KIT DE FREIO A DISCO	1GM20	08
OMEGA/SUPREMA	DIANTEIRA	KIT DE FREIO A DISCO	1GM21	08
ACD 13/20- 93/II - ACD 13/20 A	DIANTEIRA	KIT DE FREIO A DISCO	1GM22	08
ACD 13/20-93/I,II - ACD 13/20	DIANTEIRA	KIT DE FREIO A DISCO	1GM23	08
MONZA 82/KADETT/IPANEMA89/(D)	DIANTEIRA	KIT DE FREIO A DISCO	1GM24	08
MZA 92/KADETT /IPANEMA 92/95	DIANTEIRA	KIT DE FREIO A DISCO	1GM25	08
ASTRA/VECTRA97/(D)	DIANTEIRA	KIT DE FREIO A DISCO	1GM26	09
SILVERADO	DIANTEIRA	KIT DE FREIO A DISCO	1GM27	09
ASTRA99/ZAFIRA(D) RODA ARO 14	DIANTEIRA	KIT DE FREIO A DISCO	1GM28	09
A/C/D 40	DIANTEIRA	CONJUNTO DE FIXACAO DA PASTILHA	1GM29	09
S10 / BLAZER	DIANTEIRA	CONJUNTO DE MOLAS ANTIRUIDOS	1GM30	09
CORSA 02/ MERIVA 02/ MONTANNA	DIANTEIRA	CONJUNTO DE FIXACAO DA PASTILHA	1GM31	09
CELTA 01/...CORSA 94/...BLAZER	DIANTEIRA	KIT DE FREIO A DISCO	1GM32	09
COBALT LS/LT 1.4 /1.8 8V C/ABS	DIANTEIRA	KIT DE FREIO A DISCO	1GM33	09
S.10 / BLAZER ATÉ 2011	DIANTEIRA	KIT DE FREIO A DISCO	1GM34	09
S10 2012/... 1 RODA	DIANTEIRA	ALINHADOR DE PASTILHA	1GM35	09
CRUZE TDS	DIANTEIRA	ALINHADOR DE PASTILHA	1GM36	09
C/D/10 64-78 - 500KG	TRASEIRA	REPAROS CENTR.DO PATIM	2GM23	13
A/C/D/10 1.000 KG	TRASEIRA	REPAROS CENTR.DO PATIM	2GM24	13

# Aplicações por veículos para aplicadores

OPALA	TRASEIRA	REPAROS CENTR.DO PATIM	2GM25	13
CHEVETTE / CHEVY 500	TRASEIRA	REPAROS CENTR.DO PATIM	2GM27	13
MONZA/KADETT/IPANEMA	TRASEIRA	REPAROS CENTR.DO PATIM	2GM28	13
OPALA	TRASEIRA	REPAROS CENTR.DO PATIM	2GM29	13
A/C/D 20	TRASEIRA	REPAROS CENTR.DO PATIM	2GM30	13
A/C/D 40	TRASEIRA	REPAROS CENTR.DO PATIM	2GM32	14
C/D 60/80	TRASEIRA	REPAROS CENTR.DO PATIM	2GM33	14
CORSA/VECTRA 97 /TIGRA	TRASEIRA	REPAROS CENTR.DO PATIM	2GM34	14
S10 / BLAZER	TRASEIRA	REPAROS CENTR.DO PATIM	2GM35	14
A/C/D 20	TRASEIRA	REPAROS CENTR.DO PATIM	2GM36	14
ASTRA 99/...MERIVA / VECTRA /	TRASEIRA	CENTRALIZADOR DE PATIM	2GM37	14
CELTA / PRISMA PINO 31MM	TRASEIRA	CENTRALIZADOR DE PATIM	2GM38	14
CELTA / PRISMA	TRASEIRA	CENTRALIZADOR DE PATIM	2GM39	14
CHEVETE 73/86 - PINO 39MM	TRASEIRA	CENTRALIZADOR DE PATIM	2GM40	14
VECTRA 97/...	TRASEIRA	CENTRALIZADOR DE PATIM	2GM41	14
VECTRA 98/... PINO 39MM	TRASEIRA	CENTRALIZADOR DE PATIM	2GM42	14
ASTRA 99 / ZAFIRA / MERIVA - P	TRASEIRA	CENTRALIZADOR DE PATIM	2GM43	14
PALIO / CORSA	TRASEIRA	REPAROS CENTR.DO PATIM	2GT21	
CHEVET/OPALA/MONZA/KADETT	TRASEIRA	REPAROS DA SAPATA	3GM31	18
OPALA/CARAVAN 79/	TRASEIRA	REPAROS DA SAPATA	3GM33	18
CHEVETTE / CHEVY 500	TRASEIRA	REPAROS DA SAPATA	3GM35	18
A/C/D 10/20 - C14	TRASEIRA	REPAROS DA SAPATA	3GM36	18
A/C/D 40	TRASEIRA	REPAROS DA SAPATA	3GM37	18
A/C/D 60 E 80	TRASEIRA	REPAROS DA SAPATA	3GM40	18
CHEVETTE / CHEVY 500	TRASEIRA	REPAROS DA SAPATA	3GM42	18
OPALA/CARAVAN /78	TRASEIRA	REPAROS DA SAPATA	3GM43	18
OPALA/CARAVAN 79/	TRASEIRA	REPAROS DA SAPATA	3GM44	18
MONZA 82/87	TRASEIRA	REPAROS DA SAPATA	3GM45	18
KADETT/MONZA 89	TRASEIRA	REPAROS DA SAPATA	3GM46	19
MONZA 88 / PICK-UP CORSA	TRASEIRA	REPAROS DA SAPATA	3GM47	19
C/D 60 71/79	TRASEIRA	REPAROS DA SAPATA	3GM48	19
C/D 60/80	TRASEIRA	REPAROS DA SAPATA	3GM49	19
CORSA/VECTRA 97 /TIGRA	TRASEIRA	REPAROS DA SAPATA	3GM50	19
S10 / BLAZER	TRASEIRA	REPAROS DA SAPATA	3GM51	19
A/C/D 20	TRASEIRA	REPAROS DA SAPATA	3GM52	19
ASTRA 99/...MERIVA / VECTRA /	TRASEIRA	REPARO DA SAPATA	3GM53	19
VECTRA 97/...	TRASEIRA	REPARO DA SAPATA DE FREIO	3GM56	19
VECTRA 98/... ASTRA 99 /...ZAF	TRASEIRA	REPARO DA SAPATA DE FREIO	3GM57	19
CELTA / PRISMA	TRASEIRA	REPARO DA SAPATA DE FREIO	3GM58	19
ONIX/SONIC/COBALT 1.0/1.4 2002/... PRISMA 2013/...2 RODAS SIST. VARGA	TRASEIRA	REPARO DA SAPATA DE FREIO	3GM59	19
A/C/D 10/14/20 - VERANEIO	TRASEIRA	PINO DO CIL.DO FREIO	4GM41	27
D-10 D/T	TRASEIRA	PINO DO CIL.DO FREIO	4GM42	27
D40/60/80-	TRASEIRA	PINO DE PATINS (RETRACAO)	4GM43	27
C10/14-	TRASEIRA	PINO DE PATINS ( ANCORAS GROSSO)	4GM44	27
A/C/D - 10/14/15/20- VERANEIO 68/75 C 10/14/15/16	TRASEIRA	PINO ANCORAS FINO	4GM44A	28
C/D 60/80	TRASEIRA	REG.DE FREIO	4GM45D	28
C/D 60/80	TRASEIRA	REG.DE FREIO	4GM45E	28
A/C/D 10/20 - C14	TRASEIRA	REG.DE FREIO	4GM46	28
A/C/D 10/20 - C14 7/16 AUTOMAT	TRASEIRA	REG.DE FREIO	4GM46D	28
A/C/D 10/20 - C14 7/16 AUTOMAT	TRASEIRA	REG.DE FREIO	4GM46E	28
C/D 40	TRASEIRA	REG.DE FREIO	4GM47	28
KADETT/MONZA 89	TRASEIRA	REG.DE FREIO	4GM48D	28

# Aplicações por veículos para aplicadores

KADETT/MONZA 89	TRASEIRA	REG.DE FREIO	4GM48E	28
OPALA	TRASEIRA	REG.DE FREIO	4GM49D	28
OPALA	TRASEIRA	REG.DE FREIO	4GM49E	28
CHEVET / MARAJÓ	TRASEIRA	REG.DE FREIO	4GM52D	28
CHEVET / MARAJÁ	TRASEIRA	REG.DE FREIO	4GM52E	28
OPALA	TRASEIRA	REG.DE FREIO	4GM53D	28
OPALA	TRASEIRA	REG.DE FREIO	4GM53E	28
CORSA	TRASEIRA	REG.DE FREIO	4GM54D	28
CORSA	TRASEIRA	REG.DE FREIO	4GM54E	28
S10 / BLAZER	TRASEIRA	REG.DE FREIO	4GM55D	28
S10 / BLAZER	TRASEIRA	REG.DE FREIO	4GM55E	29
A/C/D-10/20-C14 - S.10/BLAZER	TRASEIRA	JG REG.AUTOMATICA	4GM56D	29
A/C/D-10/20-C14 - S.10/BLAZER	TRASEIRA	JG REG.AUTOMATICA	4GM56E	29
MONZA/KADETT/IPANEMA	TRASEIRA	REG.DE FREIO	4GM57D	29
MONZA/KADETT/IPANEMA	TRASEIRA	REG.DE FREIO	4GM57E	29
SILVERADO / D20 93/...	TRASEIRA	REG.DE FREIO	4GM58D	29
SILVERADO / D20 93/...	TRASEIRA	REG.DE FREIO	4GM58E	29
A/C/D - 10/14/15/20- VERANEIO	TRASEIRA	ALAV.ACIONAMENTO DAS SAPATAS	4GM59D	29
A/C/D - 10/14/15/20- VERANEIO	TRASEIRA	ALAV.ACIONAMENTO DAS SAPATAS	4GM59E	29
A/C/D - 10/14/15/20- VERANEIO	TRASEIRA	HASTE AC.DAS SAPATAS	4GM60	29
A/C/D 40	TRASEIRA	ALAVANCA AC.DAS SAPATAS	4GM61D	29
A/C/D 40	TRASEIRA	ALAVANCA AC.DAS SAPATAS	4GM61E	29
A/C/D 40	TRASEIRA	HASTE DE AC.DAS SAPATAS	4GM62	29
A/C/D 10/20/40 - SIVERADO	TRASEIRA	JG DE REG. AUTOMATICA	4GM63D	29
A/C/D 10/20/40 - SIVERADO	TRASEIRA	JG DE REG. AUTOMATICA	4GM63E	29
CHEVETTE	TRASEIRA	REG.DE FREIO	4GM66D	29
CHEVETTE	TRASEIRA	REG.DE FREIO	4GM66E	29
MONZA/KADETT/IPANEMA	TRASEIRA	REG.DE FREIO COMPLETO	4GM68D	30
MONZA/KADETT/IPANEMA	TRASEIRA	REG.DE FREIO COMPLETO	4GM68E	30
ASTRA 95/96 - CORSA / TIGRA	TRASEIRA	REG.DE FREIO	4GM70D	30
ASTRA 95/96 - CORSA / TIGRA	TRASEIRA	REG.DE FREIO	4GM70E	30
ASTRA 99/MERIVA/MONTANA/VECTRA	TRASEIRA	REG.DE FREIO	4GM71D	30
ASTRA 99/MERIVA/MONTANA/VECTRA	TRASEIRA	REG.DE FREIO	4GM71E	30
A/C/D 40 85/...	TRASEIRA	KIT ACIONADOR DO FREIO AUTOMATICO	4GM72D	30
A/C/D 40 85/...	TRASEIRA	KIT ACIONADOR DO FREIO AUTOMATICO	4GM72E	30
S10 12/... 2.4/2 8 4X2/4X4 1 RODA. (DIR) AUT.	TRASEIRA	REGULADOR DE FREIO	4GM73D	30
S10 12/... 2.4/2 8 4X2/4X4 1 RODA TRAS. (DIR) AUT.	TRASEIRA	REGULADOR DE FREIO	4GM73E	30
S10 12/.. 2.4 2.8 4X2 4X4 1 RODA	TRASEIRA	GATILHO DE ACIONAMENTO DE FREIO	4GM74D	30
S10 12/.. 2.4 2.8 4X2 4X4 1 RODA	TRASEIRA	GATILHO DE ACIONAMENTO DE FREIO	4GM74E	30
ONIX / SONIC / COBALT 1.0/1.4 2012/... PRISMA 2013/... 1 RODA TRAS. LD DIR SIST. VARGA	TRASEIRA	REGULADOR DE FREIO	4GM75D	30
ONIX / SONIC / COBALT 1.0/1.4 2012/... PRISMA 2013/... 1 RODA TRAS. LD ESQ. SIST. VARGA	TRASEIRA	REGULADOR DE FREIO	4GM75E	30
CHEVETTE (EMB.10 UNID.)		PINO TRAVA DA PASTILHA	5GM51	37
OPALA 72/...(EMB.10 UNID.)		PINO TRAVA DA PASTILHA	5GM52	37
VECTRA 94/96 - OMEGA		PINO TRAVA DA PASTILHA	5GM53	37
MONZA ( D )	DIAN. E TRASEIRA	PARAFUSO SANGRADOR	6GM61	38
MONZA ( T )	DIAN. E TRASEIRA	PARAFUSO SANGRADOR	6GM62	38
CORSA (D) M7X1	DIAN. E TRASEIRA	PARAFUSO SANGRADOR	6GM63	38
CORSA (T) M8X1,25	DIAN. E TRASEIRA	PARAFUSO SANGRADOR	6GM64	38
VECTRA (D) M8X1,25	DIAN. E TRASEIRA	PARAFUSO SANGRADOR	6GM65	38
VECTRA (T) M7X1	DIAN. E TRASEIRA	PARAFUSO SANGRADOR	6GM66	38
OMEGA (D) M8X1,25	DIAN. E TRASEIRA	PARAFUSO SANGRADOR	6GM67	38
OMEGA (T) M7X1	DIAN. E TRASEIRA	PARAFUSO SANGRADOR	6GM68	38
S10/BLAZER M3/8X24	DIAN. E TRASEIRA	PARAFUSO SANGRADOR	6GM69	38

# Aplicações por veículos para aplicadores

A/C/D 10	TRASEIRA	REP.SAPATA/PATIM	7GM71	41
OPALA/CARAVAN /78	TRASEIRA	REP.SAPATA/PATIM	7GM72	41
OPALA/CARAVAN 79/	TRASEIRA	REP.SAPATA/PATIM	7GM73D	41
OPALA/CARAVAN 79/	TRASEIRA	REP.SAPATA/PATIM	7GM73E	41
OPALA / CARAVAN	TRASEIRA	REP.SAPATA/PATIM	7GM74D	41
OPALA / CARAVAN	TRASEIRA	REP.SAPATA/PATIM	7GM74E	41
CHEVETTE / CHEVY 500	TRASEIRA	REP.SAPATA/PATIM	7GM75D	41
CHEVETTE / CHEVY 500	TRASEIRA	REP.SAPATA/PATIM	7GM75E	41
MONZA 82/87	TRASEIRA	REP.SAPATA/PATIM	7GM76	41
KADETT/MONZA 89	TRASEIRA	REP.SAPATA/PATIM	7GM77D	41
MONZA	TRASEIRA	REP.SAPATA/PATIM	7GM77E	41
MONZA 88/...	TRASEIRA	REP.SAPATA/PATIM	7GM78D	41
MONZA	TRASEIRA	REP.SAPATA/PATIM	7GM78E	41
CORSA	TRASEIRA	REP.SAPATA/PATIM	7GM79D	41
CORSA	TRASEIRA	REP.SAPATA/PATIM	7GM79E	41
S10 / BLAZER	TRASEIRA	REP.SAPATA/PATIM	7GM80	41
A/C/D 20	TRASEIRA	REP.SAPATA/PATIM	7GM81	41
CHEVETE 73/86 - PINO 39MM	TRASEIRA	CENTRALIZADOR / REP. DA SAPATA	7GM82D	41
CHEVETE 73/86 - PINO 39MM	TRASEIRA	CENTRALIZADOR / REP. DA SAPATA	7GM82E	42
VECTRA 97/...	TRASEIRA	CENTRALIZADOR / REP.DA SAPATA	7GM83D	42
VECTRA 97/...	TRASEIRA	CENTRALIZADOR / REP. DA SAPATA	7GM83E	42
VECTRA 98/... PINO 39MM	TRASEIRA	CENTRALIZADOR / REP. DA SAPATA	7GM84D	42
VECTRA 98/... PINO 39MM	TRASEIRA	CENTRALIZADOR / REP. DA SAPATA	7GM84E	42
ASTRA 99 / ZAFIRA / MERIVA - P	TRASEIRA	CENTRALIZADOR / REP. DA SAPATA	7GM85D	42
ASTRA 99 / ZAFIRA / MERIVA - P	TRASEIRA	CENTRALIZADOR / REP. DA SAPATA	7GM85E	42
CELTA / PRISMA	TRASEIRA	CENTRALIZADOR / REP. DA SAPATA	7GM86	42
CHEVETTE / CHEVY 500		REP.DA RODA FREIO A DISCO	8GM82	46
ASTRA 1.8/2.0/ZAFIRA /VECTRA A		REPARO DE PINCA	8GM84	46
ASTRA / ZAFIRA ARO 15		REPARO DE PINCA	8GM85	46
CORSA 1.0/1.4 94/...CELTA 00/.		REPARO DE PINCA	8GM86	46
ASTRA/ VECTRA 93/95		REPARO DE PINCA	8GM87	46
OPALA 71/92 - CARAVAN 75/92		REPARO DE PINCA	8GM88	46
CHEVETTE/MARAJÁ/CHEVY 500		REPARO DE PINCA	8GM89	46
A/C/D 40 85/97		REPARO DE PINCA	8GM90	46
CHEVETTE/MARAJÁ/CHEVY 500		REPARO DE PINCA	8GM91	47
S 10 / BLAZER 4 X 4		REPARO DE PINCA	8GM92	47
A/C/D-40 85/97		REPARO DA PINCA	9GM100	49
CHEVETE/CHEVY/MARAJÁ 08-86		REPARO DE PINCA	9GM101	49
ASTRA 1.8/2.0/ZAFIRA /VECTRA A		REPARO DE PINCA	9GM91	49
ASTRA ARO 15/ZAFIRA ARO 15		REPARO DE PINCA	9GM92	49
CORSA 1.0/1.4 94/...CELTA 00/.		REPARO DE PINCA	9GM93	49
ASTRA/ VECTRA 93/95		REPARO DE PINCA	9GM94	49
OPALA 71/92 - CARAVAN 75/92		REPARO DE PINCA	9GM98	49
CHEVETTE/MARAJÁ/CHEVY 500		REPARO DE PINCA	9GM99	49

## HONDA

VEICULO	RODA	DESCRIÇÃO	PRODUTO	PÁGINA
HONDA CIVIC 2012 A 2015	TRASEIRA	REPAROS DA SAPATA	3HO31	19
NEW CIVIC 05/...		REPARO DE PINCA	8HO81	47
NEW CIVIC 05/...		REPARO DE PINCA	8HO82	47



# Aplicações por veículos para aplicadores

HYUNDAI				
VEICULO	RODA	DESCRIÇÃO	PRODUTO	PÁGINA
HR TDS	DIANTEIRA	KIT DE FREIO A DISCO HR	1HY11	09
H100 TDS	TRASEIRA	KIT DE FREIO A DISCO H100	1HY12	09
HB20 1 RODA	DIANTEIRA	ALINHADOR DE PASTILHA	1HY13	09
TUCSON	TRASEIRA	REPARO DA SAPATA DE FREIO	3HY32	19
HYUNDAI HR	TRASEIRA	REGULADOR DE FREIO AUTOMÁTICO	4HY42D	30
HYUNDAI HR	TRASEIRA	REGULADOR DE FREIO AUTOMÁTICO	4HY42E	30
TUCSON	TRASEIRA	REGULADOR DE FREIO AUTOMÁTICO	4HY43D	31
TUCSON	TRASEIRA	REGULADOR DE FREIO AUTOMÁTICO	4HY43E	31
H100 (TDS)	TRASEIRA	REGULADOR FREIO	4HY44D	31
H100 TODOS	TRASEIRA	REGULADOR FREIO	4HY44E	31
HR 2007/...		REPARO DE PINCA	8HY81	47
TUCSON		REPARO DE PINCA	8HY82	47

IVECO				
VEICULO	RODA	DESCRIÇÃO	PRODUTO	PÁGINA
IVECO 59-12	TRASEIRA	CENTRALIZADOR DE PATIM	2IV21	14
IVECO DAILY - 1 RODA	TRASEIRA	REPARO DA SAPATA DE FREIO	3IV31	19
IVECO 59-12	TRASEIRA	REPARO DA SAPATA DE FREIO	3IV32	19
IVECO DAILY - 1 RODA	TRASEIRA	CENTRALIZADOR / REP. DA SAPATA	7IV71	42
IVECO 59-12	TRASEIRA	CENTRALIZADOR / REP. DA SAPATA	7IV72	42

KIA				
VEICULO	RODA	DESCRIÇÃO	PRODUTO	PÁGINA
BESTA GS 2.7 - 12 LUGARES	DIANTEIRA	MOLA ANTIRUIDO DA PASTILHA	1KI11	09
BESTA GS 3.0 A PARTIR 4/99 16 LUGARES	DIANTEIRA	MOLA ANTI RUIDO DA PASTILHA FREIO	1KI12	09
BESTA 2.2	DIANTEIRA	KIT DE FREIO A DISCO BESTA 2.2	1KI13	09
BESTA 3.0	DIANTEIRA	KIT DE FREIO A DISCO BESTA 3.0	1KI14	09
SORENTO 3.5 V6 2.4/2.5 CRDI	DIANTEIRA	KIT DE FREIO A DISCO	1KI15	10
BESTA/TOPIC	TRASEIRA	REPAROS CENTR.DO PATIM	2AK21	12
BESTA/TOPIC	TRASEIRA	REPAROS DA SAPATA	3AK31	16
BESTA/TOPIC	TRASEIRA	REG.DE FREIO	4AK41D	22
BESTA/TOPIC	TRASEIRA	REG.DE FREIO	4AK41E	22
SPORTAGE 95/...	TRASEIRA	GATILHO DO FREIO	4KI41D	31
SPORTAGE 95/...	TRASEIRA	GATILHO DO FREIO	4KI41E	31
BESTA/TOPIC	TRASEIRA	REP.SAPATA/PATIM	7AK71	39
BESTA GS 99/...		REPARO DE PINCA	8KI81	47

LINHAS GERAIS				
VEICULO	RODA	DESCRIÇÃO	PRODUTO	PÁGINA
MONZA/UNO/TIPO/DEL REY/PAMPA/B	DIANTEIRA	KIT DE FREIO A DISCO	1LG11	10
SANTANA/GOL/PALIO/TEMPRA/ESCOR	DIANTEIRA	KIT FREIO A DISCO	1LG12	10
F600/7000/11000	TRASEIRA	REG.DE FREIO	4LG43	31
F600/7.000/11.000/A/C/D 60/80	TRASEIRA	REP.SAPATA/PATIM	7LG71	42
F600/7.000/11.000/A/C/D 60/80	TRASEIRA	REP.SAPATA/PATIM	7LG72	42
ASTRA		REPARO PINCA FREIO	8LG01	47
ASTRA/VECTRA/UNO/TEMPRA/SIENA/		REPARO DE PINCA	8LG01	47

# Aplicações por veículos para aplicadores

CORSA/CELTA/VECTRA/ASTRA/ZAFIR		REPARO DE PINCA	8LG02	47
PALIO-WKD/SIENA/VERSAILLES/STN		REPARO DE PINCA	8LG83	47
PALIO/SIENA/WEKEND/TEMPRA/TIPO		REPARO DE PINCA	8LG84	47
ALFA 164 91/97- AUDI A3 97/...		REPARO DE PINCA	8LG85	47
ASTRA/VECTRA/UNO/TEMPRA/SIENA/		REPARO DE PINCA	9LG01	50
CORSA/CELTA/VECTRA/ASTRA/ZAFIR		REPARO DE PINCA	9LG02	50
PALIO-WKD/SIENA/VERSAILLES/STN		REPARO DE PINCA	9LG91	50
PALIO 1.0/1.5 03-98/ESCORT ZET		REPARO DE PINCA	9LG92	50
ALFA 164 91/97- AUDI A3 97/...		REPARO DE PINCA	9LG95	50

MERCEDES-BENZ				
VEICULO	RODA	DESCRIÇÃO	PRODUTO	PÁGINA
MB 608	TRASEIRA	REPAROS CENTR.DO PATIM	2MB21	14
SPRINTER	TRASEIRA	REPAROS CENTR.DO PATIM	2MB23	14
MB 180 TDS	TRASEIRA	CENTRALIZADOR DE PATIM	2MB24	15
MB 608	TRASEIRA	REPAROS DA SAPATA	3MB31	19
MB 321/1111/1113/	TRASEIRA	REPAROS DA SAPATA	3MB32	19
MB 1313/1513/2013/2213	TRASEIRA	REPAROS DA SAPATA	3MB33	20
MB 1313/1513/2013/2213	TRASEIRA	REPAROS DA SAPATA	3MB34	20
MB 321/1111/1113/	TRASEIRA	REPAROS DA SAPATA	3MB35	20
MB 1313/1513/2013	TRASEIRA	REPAROS DA SAPATA	3MB36	20
SPRINTER	TRASEIRA	REPAROS DA SAPATA	3MB37	20
MB 180 TDS	TRASEIRA	REPARO DA SAPATA DE FREIO	3MB38	20
MB 321/1111/1113/	TRASEIRA	PINO DO CILINDRO DE FREIO	4MB41	31
MB 321/1111/1113/	TRASEIRA	PINO DO CILINDRO DE FREIO	4MB42	31
MB 1313/1513/2013	TRASEIRA	PINO DA SAPATA	4MB43	31
MB 321/1111/1113/	TRASEIRA	PINO DA SAPATA	4MB44	31
MB 1111/1113/321/	TRASEIRA	PINO DA SAPATA	4MB47	31
MB 1111/1113/321/	TRASEIRA	PINO DA SAPATA	4MB48	31
MB 1111/1113/321/	TRASEIRA	PINO DA SAPATA	4MB49	31
MB 1111/1113/321/	TRASEIRA	PINO DA SAPATA	4MB50	31
MB 1313/1513/2013	TRASEIRA	PINO DA SAPATA	4MB51	32
MB 1313/1513/2013	TRASEIRA	PINO DA SAPATA	4MB52	32
MB 321/1111/1113/	TRASEIRA	REG.DE FREIO	4MB53	32
MB 1313/1513/2013/2213	TRASEIRA	REG.DE FREIO (CURTO)	4MB54	32
MB 1313/1513/2013/2213	TRASEIRA	REG.DE FREIO (LONGO)	4MB55	32
L 608	TRASEIRA	REG.DE FREIO	4MB56	32
MB 321/1111/1113/	TRASEIRA	REG.DE FREIO (SININHO)	4MB57	32
MB 608/708/709/912	TRASEIRA	HASTE DO FREIO-DE-MAO	4MB58	32
MB 608/708/709/912	TRASEIRA	ALAVANCA DA SAP.DE FREIO	4MB59D	32
MB 608/708/709/912	TRASEIRA	ALAVANCA DA SAP.DE FREIO	4MB59E	32
MB 608/708/709/912	TRASEIRA	KIT DE FIXACAO DA SAPATA	4MB60	32
MB 1113	TRASEIRA	ALAVANCA DA SAP.DE FREIO	4MB61	32
SPRINTER	TRASEIRA	REG.DE FREIO	4MB62D	32
SPRINTER	TRASEIRA	REG.DE FREIO	4MB62E	32
SPRINTER	TRASEIRA	REG.DE FREIO	4MB63D	32
SPRINTER	TRASEIRA	REG.DE FREIO	4MB63E	32
SPRINTER	TRASEIRA	JG.ALAVANCAS DE ACIONAMENTO DO PATIM	4MB65D	32
SPRINTER	TRASEIRA	JG.ALAVANCAS DE ACIONAMENTO DO PATIM	4MB65E	32
MB 180 TDS	TRASEIRA	REG.DE FREIO	4MB66D	33
MB 180 TDS	TRASEIRA	REG. DE FREIO	4MB66E	33
MB 608 / 709 M8X1,25	DIANTEIRA E TRAS.	PARAFUSO SANGRADOR	6MB61	38

# Aplicações por veículos para aplicadores

MB 608	TRASEIRA	REP.SAPATA/PATIM	7MB71	42
SPRINTER	TRASEIRA	REP.SAPATA/PATIM	7MB72	42
MB 180 TDS	TRASEIRA	CENTRALIZADOR / REP. DA SAPATA	7MB73	42
SPRINTER		REPARO DE PINCA	8MB81	47
SPRINTER 310 / 312 97/...		REPARO DE PINCA	8MB83	47
SPRINTER 312 99/...		REPARO DE PINCA	8MB84	47
SPRINTER		REPARO DE PINCA	9MB91	50

## MITSUBISHI

VEICULO	RODA	DESCRIÇÃO	PRODUTO	PÁGINA
MITSUBISHI L 200 4X4 92/96 L.200 A PARTIR 06/96 GL	DIANTEIRA	MOLA ANTIRUIDO	1MI11	10
L200 SPORT 2003 ATE 2007	DIANTEIRA	ALINHADOR DE PASTILHA DE FREIO DIANTEIRO	1MI12	10
L.200 TRITON	DIANTEIRA	ALINHADOR DE PASTILHA DE FREIO	1MI13	10
L.200 / L.300 EXC. SPORT	TRASEIRA	CENTRALIZADOR DE PATIM	2MI21	14
L.200 EXCERTO TRITON E SPORT	TRASEIRA	CENTRALIZADOR DE PATIM	2MI22	14
L.200 SPORT / PAJERO SPORT	TRASEIRA	CENTRALIZADOR DE PATIM	2MI23	15
PAJERO 2.8 TD,3.0 V6 - 3.5 V6	TRASEIRA	CENTRALIZADOR DE PATIM	2MI24	15
SPIN 1T 1.8 12/... TRACKER 1.10	TRASEIRA	CENTRALIZADOR DE FREIO	2MI25	15
L 200 ( TDS )	TRASEIRA	REPARO DA SAPATA	3MI32	20
L.200 SPORT / PAJERO SPORT	TRASEIRA	REPARO DA SAPATA DE FREIO	3MI33	20
PAJERO 2.8 TD,3.0 V6 - 3.5 V6	TRASEIRA	REPARO DA SAPATA DE FREIO	3MI34	20
L.200 TRITON	TRASEIRA	REPARO DA SAPATA DE FREIO	3MI35	20
SPIN 1T 1.8 12/... TRACKER 1.10	TRASEIRA	REPARO DA SAPATA DE FREIO	3MI36	20
L 200 EXCERTO SPORT	TRASEIRA	REGULADOR DE FREIO	4MI41D	33
L 200 EXCERTO SPORT	TRASEIRA	REGULADOR DE FREIO	4MI41E	33
L 200 / L 300 EXCERTO SPORT	TRASEIRA	GATILHO DO FREIO	4MI42D	33
L 200 / L 300 EXCERTO SPORT	TRASEIRA	GATILHO DO FREIO	4MI42E	33
L.200 SPORT / OUTDOOR / PAJERO	TRASEIRA	REGULADOR DE FREIO AUTOMATICO	4MI43D	33
L.200 SPORT / OUTDOOR / PAJERO	TRASEIRA	REGULADOR DE FREIO AUTOMATICO	4MI43E	33
L.200 TRITON 3.2 / 3.5 08/...	TRASEIRA	REGULADOR DE FREIO AUTOMATICO	4MI44D	33
L.200 TRITON 3.2 / 3.5 08/...	TRASEIRA	REGULADOR DE FREIO AUTOMATICO	4MI44E	33
L.200 SPORT / OUTDOOR / PAJERO	TRASEIRA	ACIONADOR DE FREIO AUTOMATICO	4MI45D	33
L.200 SPORT / OUTDOOR / PAJERO	TRASEIRA	ACIONADOR DE FREIO AUTOMATICO	4MI45E	33
L200 TRITON 3.2/3.5 08/... 1 RODA DIR	TRASEIRA	GATILHO DE ACIONAMENTO DE FREIO	4MI46D	33
L200 TRITON 3.2 / 3.5 08/... 1 RODA ESQ	TRASEIRA	GATILHO DE ACIONAMENTO DE FREIO	4MI46E	33
SPIN 1T 1.8 12/... TRACKER 1.8	TRASEIRA	REGULADOR DE FREIO	4MI47D	33
SPIN 1T 1.8 12/... TRACKER 1.8	TRASEIRA	REGULADOR DE FREIO	4MI47E	33
L.200 EXCERTO TRITON E SPORT	TRASEIRA	CENTRALIZADOR / REP. DA SAPATA	7MI71D	42
L.200 EXCERTO TRITON E SPORT	TRASEIRA	CENTRALIZADOR / REP. DA SAPATA	7MI71E	43
L.200 SPORT / PAJERO SPORT	TRASEIRA	CENTRALIZADOR / REP. DA SAPATA	7MI72	43
PAJERO 2.8 TD,3.0 V6 - 3.5 V6	TRASEIRA	CENTRALIZADOR / REP. DA SAPATA	7MI73	43
SPIN 1T 1.8 12/... TRACKER 1.10	TRASEIRA	REPARO DA SAPATA/PATIM	7MI74D	43
SPIN 1T 1.8 12/... TRACKER 1.10	TRASEIRA	REPARO DA SAPATA/PATIM	7MI74E	43
L 200 SPORT 04/...		REPARO DE PINCA	8MI81	47
PAJERO SPORT 98/...		REPARO DE PINCA	8MI82	48

## NISSAN

VEICULO	RODA	DESCRIÇÃO	PRODUTO	PÁGINA
FRONTIER	DIANTEIRA	MOLA ANTIRUIDO (INOX )	1NI11	10
NISSAN FRONTIER 2009/... 1 RODA	DIANTEIRA	ALINHADOR DE PASTILHA	1NI12	10

# Aplicações por veículos para aplicadores

NISSAN FRONTIER 03/...	TRASEIRA	CENTRALIZADOR DE PATIM	2NI21	15
FRONTIER 08/12... PATHFINDER 96/99	TRASEIRO	CENTRALIZADOR DE FREIO	2NI22	15
NISSAN FRONTIER 03/...	TRASEIRA	REPARO DA SAPATA DE FREIO	3NI31	20
FRONTIER 08/12... PATHFINDER 96/99	TRASEIRA	REPARO DA SAPATA DE FREIO	3NI32	20
FRONTIER	TRASEIRA	REGULADOR DE FREIO AUTOMÁTICO	4NI41D	33
FRONTIER	TRASEIRA	REGULADOR DE FREIO AUTOMÁTICO	4NI41E	33
FRONTIER 08/12... PATHFINDER 96/99	TRASEIRA	REGULADOR DE FREIO	4NI42D	33
FRONTIER 08/12... PATHFINDER 96/99	TRASEIRA	REGULADOR DE FREIO	4NI42E	33
NISSAN FRONTIER 03/...	TRASEIRA	CENTRALIZADOR / REP. DA SAPATA	7NI71	43
FRONTIER 08/12... PATHFINDER 96/99	TRASEIRA	REPARO DA SAPATA/PATIM	7NI72	43

## PEUGEOT

VEICULO	RODA	DESCRIÇÃO	PRODUTO	PÁGINA
PEUGEOT307/308... 1 RODA	DIANTEIRA	ALINHADOR DE PASTILHA	1PG21	10
PEUGEOT 206 / 207	TRASEIRA	CENTRALIZADOR DE PATIM	2PG21	15
PEUGEOT 504 TDS - PINO 28MM	TRASEIRA	CENTRALIZADOR DE PATIM	2PG22	15
PEUGEOT 206 / 207	TRASEIRA	REPARO DA SAPATA DE FREIO	3PG31	20
PEUGEOT 504 TDS	TRASEIRA	REPARO DA SAPATA DE FREIO	3PG32	20
206 SW 05/09 - 207 SW 09/... 1 RODA TRAS.	TRASEIRA	REGULADOR DE FREIO	4PG41D	34
206 SW 05/09 - 207 SW 09/... 1 RODA TRAS.	TRASEIRA	REGULADOR DE FREIO	4PG41E	34
PEUGEOT 206/207 HOGGAR 1 RODA (D)	TRASEIRA	REGULADOR DE FREIO	4PG43D	34
PEUGEOT 206/207 HOGGAR 1 RODA (E)	TRASEIRA	REGULADOR DE FREIO	4PG43E	34
PEUGEOT 504, 505	TRASEIRA	REP.SAPATA/PATIM	7PG71	43
PEUGEOT 206 / 207	TRASEIRA	CENTRALIZADOR / REP. DA SAPATA	7PG72D	43
PEUGEOT 206 / 207	TRASEIRA	CENTRALIZADOR / REP. DA SAPATA	7PG72E	43
PEUGEOT 504 TDS - PINO 28MM	TRASEIRA	CENTRALIZADOR / REP. DA SAPATA	7PG73D	43
PEUGEOT 504 TDS - PINO 28MM	TRASEIRA	CENTRALIZADOR / REP. DA SAPATA	7PG73E	43

## RENAULT

VEICULO	RODA	DESCRIÇÃO	PRODUTO	PÁGINA
RENAULT TRAFIC	DIANTEIRA	KIT DE FREIO A DISCO	1RN11	10
RENAULT 19	DIANTEIRA	KIT DE FREIO A DISCO	1RN12	10
RENAULT TWINGO	DIANTEIRA	KIT DE FREIO A DISCO	1RN13	10
RENAULT SANDERO	TRASEIRA	CENTRALIZADOR DE PATIM	2RN21	15
RENAULT TRAFIC	TRASEIRA	REPAROS DA SAPATA	3RN31	20
RENAULT SANDERO	TRASEIRA	REPARO DA SAPATA	3RN32	20
RENAULT TRAFIC	TRASEIRA	REPARO DA SAPATA DE FREIO	3RN33	20
CLIO 90/96 - R19 92/96 TWINGO	TRASEIRA	REG.DE FREIO	4RN41D	34
CLIO 90/96 - R19 92/96 TWINGO	TRASEIRA	REG.DE FREIO	4RN41E	34
SCENIC/MEGANE/LAGUNA	TRASEIRA	REG.DE FREIO	4RN42D	34
SCENIC/MEGANE/LAGUNA	TRASEIRA	REG.DE FREIO	4RN42E	34
R19 RT / KANGOO / DUSTER - TODOS	TRASEIRA	REG.DE FREIO	4RN43D	34
R19 RT / KANGOO / DUSTER - TODOS	TRASEIRA	REG.DE FREIO	4RN43E	34
RENAULT EXPRESS	TRASEIRA	REG.DE FREIO	4RN44D	34
RENAULT EXPRESS	TRASEIRA	REG.DE FREIO	4RN44E	34
CLIO	TRASEIRA	REG.DE FREIO SIST.VARGA	4RN45D	34
CLIO	TRASEIRA	REG.DE FREIO SIST.VARGA	4RN45E	34
TRAFIC	TRASEIRA	JG.DE REGULAGEM DE FREIO	4RN46D	34
TRAFIC	TRASEIRA	JG.DE REGULAGEM DE FREIO	4RN46E	34
SANDERO / LOGAN RODA TRASEIRA	TRASEIRA	REGULADOR DE FREIO	4RN47D	34
SANDERO / LOGAN 08/...	TRASEIRA	REGULADOR DE FREIO	4RN47E	35
RENAULT	TRASEIRA	REPSAPATA/PATIM	7RN71	43

# Aplicações por veículos para aplicadores

RENAULT 19	TRASEIRA	REP.SAPATA/PATIM	7RN72D	43
RENAULT 19	TRASEIRA	REP.SAPATA/PATIM	7RN72E	43
RENAULT 19	TRASEIRA	REP.SAPATA/PATIM	7RN73	43
RENAULT EXPRESS	TRASEIRA	REP.SAPATA/PATIM	7RN74	43
RENAULT EXPRESS	TRASEIRA	REP.SAPATA/PATIM	7RN75	43
RENAULT SANDERO	TRASEIRA	REPARO DE PATIM / SAPATA	7RN76D	44
RENAULT SANDERO	TRASEIRA	REPARO DE PATIM / SAPATA	7RN76E	44
SCENIC 99/... MÉGANE 97/...	TRASEIRA	REPARO DE PINCA	8RN81	48
KANGOO 1.2 / 1.4 / 1.6	TRASEIRA	REPARO DE PINCA	8RN82	48

## TOYOTA

VEICULO	RODA	DESCRIÇÃO	PRODUTO	PÁGINA
HILLUX SW	DIANTEIRA	KIT DE FREIO A DISCO	1TY11	10
HILUX 04	DIANTEIRA	MOLA ANTIRUIDO ( INOX )	1TY12	10
COROLLA 2003/08	DIANTEIRA	MOLA ANTI RUIDO DA PASTILHA	1TY13	10
COROLLA 2003/08	DIANTEIRA	MOLA ANTIRUIDO DA PASTILHA	1TY14	10
COROLLA 98/02	DIANTEIRA	KIT DE FREIO A DISCO	1TY15	10
COROLLA 2003/...08 DIANTEIRA	DIANTEIRA	KIT DE FREIO A DISCO	1TY16	10
COROLLA 2009/...2014 DIANTEIRA	DIANTEIRA	KIT DE FREIO A DISCO	1TY17	10
HILUX 4X2 / 4X4 2009/2012 1 RODA	DIANTEIRA	ALINHADOR DE PASTILHA	1TY18	11
HILUX 4X2 / 4X4 2013/... 1 RODA	DIANTEIRA	ALINHADOR DE PASTILHA	1TY19	11
COROLLA 2008/... 1 RODA	DIANTEIRA	ALINHADOR DE PASTILHA	1TY20	11
TOYOTA BANDEIRANTE	TRASEIRA	REPAROS CENTR.DO PATIM	2TY21	15
HILUX 05/...	TRASEIRA	CENTRALIZADOR DE PATIM	2TY22	15
COROLLA 2003/08	TRASEIRA	CENTRALIZADOR DE PATIM	2TY23	15
HILUX 05/...	TRASEIRA	CENTRALIZADOR DE PATIM	2TY24	15
ETIOS	TRASEIRA	REPARO DA SAPATA	2 TY25	15
TOYOTA	TRASEIRA	REPAROS DA SAPATA	3TY31	21
HILUX 05/...	TRASEIRA	REPARO DA SAPATA	3TY32	21
ETIOS	TRASEIRA	REPARO DA SAPATA	3TY34	21
TOYOTA ATÉ 10/80	TRASEIRA	REG.DE FREIO	4TY41	35
TOYOTA 80/94 1 POLEGADA	TRASEIRA	REG.DE FREIO	4TY42	35
TOYOTA 80/94 7/8	TRASEIRA	REG.DE FREIO	4TY43	35
HILUX 4X2	TRASEIRA	REGULADOR DE FREIO	4TY45D	35
HILUX 4X2	TRASEIRA	REGULADOR DE FREIO	4TY45E	35
HILUX 05/...	TRASEIRA	REGULADOR DE FREIO	4TY46D	35
HILUX 05/...	TRASEIRA	REGULADOR DE FREIO	4TY46E	35
HILUX 4X4 AUTOMÁTICA ATÉ 04	TRASEIRA	REGULADOR DE FREIO	4TY48D	35
HILUX 4X4 AUTOMÁTICA ATÉ 04	TRASEIRA	REGULADOR DE FREIO	4TY48E	35
HILUX 4X2	TRASEIRA	KIT ACIONADOR DE FREIO AUTOMATICO	4TY49	35
HILUX 2005/...		PINO TRAVA DA PASTILHA	5TY51	37
TOYOTA	TRASEIRA	REP.SAPATA/PATIM	7TY71	44
HILUX 05/...	TRASEIRA	CENTRALIZADOR / REP. DA SAPATA	7TY72	44
ETIOS	TRASEIRA	REPARO DA SAPATA	7TY73D	44
ETIOS	TRASEIRA	REPARO DA SAPATA	7TY73E	44
COROLLA 2003/...		REPARO DE PINCA	8TY81	48
COROLLA 2003/...		REPARO DE PINCA	8TY82	48

## VOLKSWAGEN

VEICULO	RODA	DESCRIÇÃO	PRODUTO	PÁGINA
PST/GOL/VOYAGE	DIANTEIRA	KIT DE FREIO A DISCO	1VW11	11
SEDAN/BRASILIA/VARIANT	DIANTEIRA	KIT DE FREIO A DISCO	1VW12	11

# Aplicações por veículos para aplicadores

KOMBI 1600	DIANTEIRA	KIT DE FREIO A DISCO	1VW13	11
SANTANA/GOL/VOYAGE 1.8	DIANTEIRA	KIT DE FREIO A DISCO	1VW14	11
PST/GOL/VOYAGE/SAVEIRO 94	DIANTEIRA	KIT DE FREIO A DISCO	1VW16	11
PST/GOL/VOYAGE/PARATI/SAVEIRO	DIANTEIRA	KIT DE FREIO A DISCO	1VW17	11
PST/GOL/VOYAGE/PARATI/SAVEIRO	DIANTEIRA	KIT DE FREIO A DISCO	1VW18	11
PST/GOL/VOYAGE	DIANTEIRA	KIT FREIO A DISCO	1VW19	11
PST/GOL/VOYAGE	DIANTEIRA	KIT DE FREIO A DISCO	1VW20	11
SEDAN/BRASILIA/VARIANT	DIANTEIRA	KIT DE FREIO A DISCO	1VW21	11
KOMBI 1600 APOS 04/82 COMPLETO. 2RODAS	DIANTEIRA	KIT DE FREIO A DISCO	1VW22	11
SANTANA/QUANTUM	DIANTEIRA	KIT DE FREIO A DISCO	1VW23	11
GOLF/POLO	DIANTEIRA	KIT DE FREIO A DISCO	1VW24	11
GOLF / A3 / BORA / NEW BEETLE	DIANTEIRA	KIT DE FREIO A DISCO	1VW25	11
AMAROK	TRASEIRA	ALINHADOR DE PASTILHA DE FREIO	1VW26	11
TEMPRA/BRASILIA/1500/1600	TRASEIRA	REPAROS CENTR.DO PATIM	2FV21	
SEDAN 1200/1300	TRASEIRA	REPAROS CENTR.DO PATIM	2VW21	15
SEDAN 1200/1300	TRASEIRA	REPAROS CENTR.DO PATIM	2VW22	15
KOMBI 1500/1600	TRASEIRA	REPAROS CENTR.DO PATIM	2VW23	15
VW 1500/1600/BRASILIA	TRASEIRA	REPAROS CENTR.DO PATIM	2VW24	15
PST/GOL/PRT/VOY/SANTANA	TRASEIRA	REPAROS CENTR.DO PATIM	2VW25	15
PST ATE 78/ GOL/VOYAGE	TRASEIRA	REPAROS CENTR.DO PATIM	2VW26	16
PASSAT 79 EM DIANTE	TRASEIRA	REPAROS CENTR.DO PATIM	2VW27	16
KOMBI 1.6	TRASEIRA	REPAROS CENTR.DO PATIM	2VW28	16
KOMBI 1600 APOS 04/82	TRASEIRA	REPAROS CENTR.DO PATIM	2VW29	16
KOMBI 1500/1600	TRASEIRA	REPAROS CENTR.DO PATIM	2VW30	16
PASSAT 10-78/	TRASEIRA	REPAROS CENTR.DO PATIM	2VW31	16
VW 6.80/6.90/7.90/7.110	TRASEIRA	REPAROS CENTR.DO PATIM	2VW32	16
VW 11130	TRASEIRA	REPAROS CENTR.DO PATIM	2VW33	16
GOLF/POLO	TRASEIRA	REPAROS CENTR.DO PATIM	2VW34	16
SEDAN 1200/1300	TRASEIRA	REPAROS DA SAPATA	3VW31	21
SEDAN/1300/1500/1600	TRASEIRA	REPAROS DA SAPATA	3VW32	21
BRASILIA/VARIANT/TL	TRASEIRA	REPAROS DA SAPATA	3VW33	21
PST/78-VOYAGE/PARATI(06/86)GOL	TRASEIRA	REPAROS DA SAPATA	3VW34	21
PST/78-VOYAGE/PARATI(06/86)GOL	TRASEIRA	REPAROS DA SAPATA	3VW35	21
GOL(DE 83 A 6/88)VY/PARATI (83	TRASEIRA	REPAROS DA SAPATA	3VW36	21
PST/78-VOY E PARATI/82	TRASEIRA	REPAROS DA SAPATA	3VW37	21
GOL(DE 83 A 6/88)VY/PARATI (83	TRASEIRA	REPAROS DA SAPATA	3VW38	21
PST 79/ PARATI 86/ GOL 88 /SAN	TRASEIRA	REPAROS DA SAPATA	3VW39	21
KOMBI 1600 04/82	TRASEIRA	REPAROS DA SAPATA	3VW40	21
KOMBI 1600 ATÉ 04/82	TRASEIRA	REPAROS DA SAPATA	3VW41	21
KOMBI 1600 APÀS 04/82	TRASEIRA	REPAROS DA SAPATA	3VW42	21
VW 11130	TRASEIRA	REPAROS DA SAPATA	3VW43	21
VW 11130	TRASEIRA	REPAROS DA SAPATA	3VW44	21
VW 6.80/6.90/7.90/7.110	TRASEIRA	REPAROS DA SAPATA	3VW45	22
GOL/SANTANA 94/	TRASEIRA	REPAROS DA SAPATA	3VW46	22
GOLF/POLO	TRASEIRA	REPAROS DA SAPATA	3VW47	22
VERSALLES/GOL/GOLF/PARATI/ROYA	TRASEIRA	HASTE DO PATIM	4FW41D	27
VERSALLES/GOL/GOLF/PARATI/ROYA	TRASEIRA	HASTE DO PATIM	4FW41E	27
SEDAN / BRASILIA	TRASEIRA	REG.DE FREIO	4VW41	35
KOMBI 1500/1600	TRASEIRA	REG.DE FREIO	4VW42	35
PASSAT / GOL / VOYAGE	TRASEIRA	REG.DE FREIO	4VW43D	35
PST/GOL/VOYAGE/	TRASEIRA	REG.DE FREIO	4VW43E	35
VW 11130	TRASEIRA	PINO DO CIL.DE FREIO	4VW44	36

# Aplicações por veículos para aplicadores

VW 6.80/6.90/7.90/7.110	TRASEIRA	REG.DE FREIO	4VW45	36
VW 6.80/6.90/7.90/7.110	TRASEIRA	REG.DE FREIO	4VW46D	36
VW 6.80/6.90/7.90/7.110	TRASEIRA	REG.DE FREIO	4VW46E	36
VW 11130	TRASEIRA	REG.DE FREIO	4VW47D	36
VW 11130	TRASEIRA	REG.DE FREIO	4VW47E	36
VW 6.80/6.90/7.90/7.110	TRASEIRA	KIT ALAV.DA SAPATA	4VW48D	36
VW 6.80/6.90/7.90/7.110	TRASEIRA	KIT ALAV.DA SAPATA	4VW48E	36
SEDAN 1.3/1.5.1.6 -BRASILIA	TRASEIRA	ALAVANCA DE FREIO	4VW49D	36
SEDAN 1.3/1.5.1.6 -BRASILIA	TRASEIRA	ALAVANCA DE FREIO	4VW49E	36
KOMBI 82/...	TRASEIRA	ALAVANCA DE FREIO	4VW50D	36
KOMBI 82/...	TRASEIRA	ALAVANCA DE FREIO	4VW50E	36
KOMBI 1600	TRASEIRA	ALAVANCA DE FREIO	4VW52D	36
KOMBI 1600	TRASEIRA	ALAVANCA DE FREIO	4VW52E	36
SEDAN / BRASILIA		PINO TRAVA DA PASTILHA	5VW51	37
KOMBI 1500/1600		PINO TRAVA DA PASTILHA	5VW52	37
PST/GOL/VOYAGE/		PINO TRAVA DA PASTILHA	5VW53	37
PST/GOL/VOYAGE/PARATI/SAVEIRO		PINO TRAVA DA PASTILHA	5VW54	37
PST/ GOL / SAV (T)/ FIAT(T)/ B	DIANTEIRA E TRAS.	PARAFUSO SANGRADOR	6FW61	38
PST/GOL/PRT/VOY/SANTANA	DIANTEIRA E TRAS.	PARAFUSO SANGRADOR	6VW61	38
SEDAN/BRASILIA/VARIANT	DIANTEIRA E TRAS.	PARAFUSO SANGRADOR	6VW62	38
GOL/VOYAGE/PARATI/SAVEIRO	DIANTEIRA E TRAS.	PARAFUSO SANGRADOR	6VW63	38
GOL/SAV/VOY/VARIANT/BRAS.	DIANTEIRA E TRAS.	PARAFUSO SANGRADOR	6VW64	38
SEDAN 1200/1300	TRASEIRA	REP.SAPATA/PATIM	7VW71	44
SEDAN/1300/1500/1600	TRASEIRA	REP.SAPATA/PATIM	7VW72	44
VW 1500/1600/BRASILIA	TRASEIRA	REP.SAPATA/PATIM	7VW73	44
KOMBI 1600 ATÉ 04/82	TRASEIRA	REP.SAPATA/PATIM	7VW74	44
KOMBI 1600 APÁS 04/82	TRASEIRA	REP.SAPATA/PATIM	7VW75	44
KOMBI 1600	TRASEIRA	REP.SAPATA/PATIM	7VW76	44
PASSAT / GOL / VOYAGE	TRASEIRA	REP.SAPATA/PATIM	7VW77	44
GOLF/POLO	TRASEIRA	REP.SAPATA/PATIM	7VW78	44
GOL/SANTANA 94/	TRASEIRA	REP.SAPATA/PATIM	7VW79	44
PST 79/ PARATI 86/ GOL 88 /SAN	TRASEIRA	REP.SAPATA/PATIM	7VW80	44
KOMBI 82/...	TRASEIRA	REP.SAPATA/PATIM	7VW81	44
VW 6.80/6.90/7.90/7.110	TRASEIRA	REP.SAPATA/PATIM	7VW82	44
GOLF/POLO	TRASEIRA	REP.SAPATA/PATIM	7VW83	45
KADETT 12-96/GOL 1.8/PARATI 1.		REPARO DE PINCA	8GW11	47
CORSA WIND 1.0/GOL 1.0		REPARO DE PINCA	8GW12	47
GOL 80/ PST 73/88- PARATI 83 /		REP.DA RODA FREIO A DISCO	8VW82	48
GOL/VOYAGE/PARATI/SAVEIRO		REPARO DE PINCA	8VW84	48
GOLF 1.6/1.8/2.0 IV/AUDI A3		REPARO DE PINCA	8VW85	48
SEDAN/BRASILIA/VARIANT		REPARO DE PINCA	8VW86	48
FUSCA 70/96		REPARO DE PINCA	8VW87	48
KOMBI 82/ GURGEL G15 82/84		REPARO DE PINCA	8VW88	48
GOL 80/...-PASSAT 74/86 - PARA		REPARO DE PINCA	8VW90	48
ELBA 86/PREMIO 85/UNO/FIOR 88/		REPARO DE PINCA	9FW92	49
KADETT 12-96/GOL 1.8/PARATI 1.		REPARO DE PINCA	9GW11	50
CORSA WIND 1.0/GOL 1.0		REPARO DE PINCA	9GW12	50
GOL 80/ PST 73/88- PARATI 83 /		REPARO DE PINCA	9VW100	50
GOL/VOYAGE/PARATI/SAVEIRO		REPARO DE PINCA	9VW91	50
GOLF 1.6/1.8/2.0 IV/AUDI A3		REPARO DE PINCA	9VW92	50
BRASILIA/VARIANT/TL		REPARO DE PINCA	9VW96	50
FUSCA 70/96		REPARO DE PINCA	9VW97	50
KOMBI 82/ GURGEL G15 82/84		REPARO DE PINCA	9VW98	50

## TRAVAMENTO E DESGASTE DO PINO GUIA COLOCAM EM RISCO O SISTEMA DE FREIOS

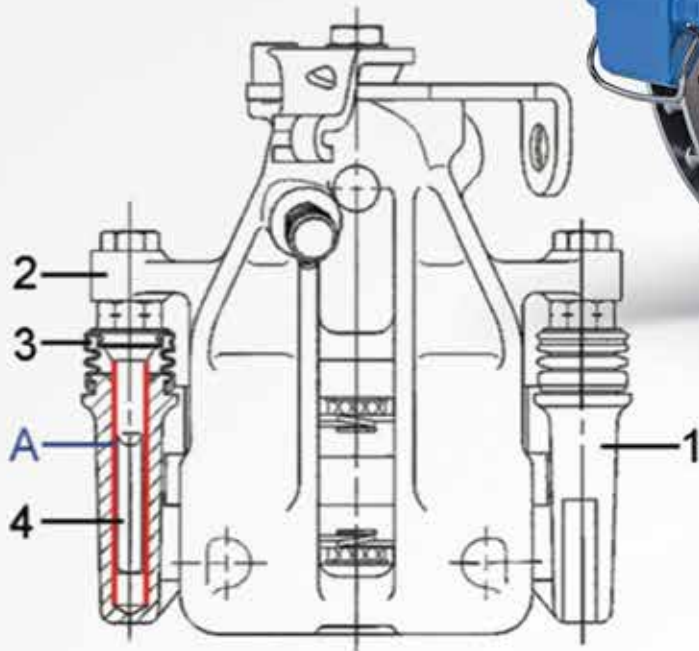

1. Corpo posterior do cavalete que abriga o pino guia;
  2. Corpo anterior do cavalete que fixa a cabeça do pino guia;
  3. Guarda-pó do pino guia que protege o sistema lubrificado contra ações do tempo;
  4. Corpo do Pino Guia que alinha o sistema de freios para performance e desgaste uniforme da pastilha;
- A. Zinabre, oxidação e poeira.

O conjunto de pino guia da pinça de freio tem função essencial na vida útil da pastilha, pois garante que o componente sofra um desgaste uniforme, preservando a vida útil da pastilha, da pinça e do cavalete de freio. O pino guia faz com que o cavalete e a pastilha se movimentem perpendicularmente ao disco de freio, proporcionando uma parada segura e precisa para os ocupantes do automóvel. É natural que, com os movimentos repetidos, a alta temperatura e a exposição hostil às ações do tempo, o guarda-pó se rompa ou ceda espaço, permitindo que as ações do tempo resultem num desgaste precoce do pino guia, causando o travamento ou fazendo com que a pastilha, o disco de freio, a pinça e o cavalete tragam prejuízos ao usuário por falta de manutenção. Por isso, hoje, um dos itens mais trocados no sistema de freios, depois da pastilha, é o conjunto de bucha e pino guia da pinça. O que gera grandes oportunidades para os distribuidores e varejistas de autopeças. **2MC a mais completa linha de reparos de vedação de pinça do mercado.**







UMA União de Marcas Automotivas Ltda

**Divisão 2MC Autocomponentes**

Rua José Furtado de Mendonça 107 CEP 05634 120 São Paulo SP

55 11 5513 0856 vendas@2mc.com.br www.2mc.com.br